

JAMISON

# RCA Broadcast News

Volume 172

Broadcast and Teleproduction Happenings



**DICK BELBER,**  
ENG Operator,  
WKBS-TV,  
Philadelphia, Pa.

**HAWKEYE:**  
ENG Mobility,  
EFP Quality  
**WISH-TV**  
Extends Automation

**TK-47**  
On-Location Reports

**CENTURY III's**  
New Supersuite

# CAMERA ONLY... OR RECORDING CAMERA



## HAWKEYE YOUR WAY

Think about it.

With HAWKEYE, you can choose either a camera or a recording camera.

If you're looking for a camera only, select the HAWKEYE HC-1. A tough, lightweight camera that delivers the kind of performance and features you need. One that works with your present cameras and recorders. That readily adapts to your triax, multicore and genlock applications with a simple change of an accessory. And, if desired, you can add the recorder later.

Or, start right off with the recording camera, the HCR-1. Add more versatility with HAWKEYE studio recorders and editing system. Get all the mobility, reliability and superior video quality of ChromaTrak recordings.

Choose HAWKEYE Your Way... how you want it, when you want it.

**CALL YOUR RCA  
REPRESENTATIVE**

OR WRITE RCA, BLDG. 2-2, CAMDEN, NJ 08102

**RCA**

## CONTENTS

### 5 Total Automation for WISH-TV

The combined technical and business automation system operated by WISH-TV provides total automation from order entry to billing—including switching and machine operations. System features and advantages are covered.

### 10 Four Field Stations Switch To HAWKEYE For ENG

In expanding local news coverage, Field Communications looked for "a field system compact enough for easy adaption to a one-man crew". HAWKEYE Recording Camera Systems provide the solution at the four Field stations covered here.



### 15 Mississippi ETV Achieves Quality EFP Results With HAWKEYE System

High quality video productions and major cost savings are mutually-compatible results that are being realized by METV with their HAWKEYE system. This article covers the cost-effective system performance.



### 18 TK-47 Automatics On-Location

The combination of superb picture quality, reliable operation and fast, automatic set-ups have made the TK-47 as popular on-location as in the studio. This report capsules several TK-47 systems used for covering remotes.

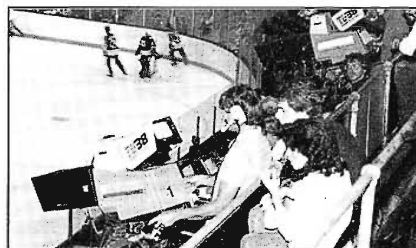

### 24 Independent WSBK-TV Operates Eight TK-47's

With its popular programming schedule, Storer Broadcasting's TV-38 in Boston performs well against strong competition. Effective use of eight TK-47 cameras in the field and studio enhances the station's competitive posture.

### 28 Century III Teleproductions Adds Capabilities

This fast-growing Boston operation has added a sophisticated new "Supersuite" with over \$1 million in state-of-art equipment, including a battery of TR-800 VTR's which are highlighted in this facility report.



### 31 Compact Mobile TV Unit Covers Ecuador

Teleamazonas, Ch. 4 in Quito, uses this self-contained mobile TV unit to produce a full schedule of sports and entertainment programming from numerous remote locations.

### 33 New Biasing Corrector Circuit For TV Transmitters

Developing the TTG-Series VHF TV Transmitters with 1600 W solid-state driver required new bias corrector circuit designs. This article explores the design/development process.

# RCA

## TVS-Channel 4 Inaugurates CP Broadcasting In Brazil



**#1 IN BRAZIL.** TVS-Channel 4, Sao Paulo is the first TV station in Brazil to broadcast a circularly polarized signal. The station is a part of the SBT Network (Sistema Brasileiro de Televisao). Present at the inauguration of CP operation are (left to right): Mr. Eliazar Patricio, President of Board of Directors of SBT; Mr. J. Gimbel, RCA Director, International Broadcast Systems Marketing; Mr. Antonio F. Neiva, General Director of DENTEL; Mr. Luciano Callegari, Vice-President of SBT; Mr. L. Scheiner, RCA District Manager, Brazil. In the background is the station's TTG-30/30L, 60 kW Transmitter.

TVS-Channel 4, Sao Paulo, has become Brazil's first television station to broadcast a circularly polarized signal.

Owned and operated by Sistema Brasileiro de Televisao network, the station is transmitting with a new RCA TTG-30/30L 60-kilowatt transmitter and TFV-7A4 circularly polarized antenna.

The new transmitting system eliminated several re-transmissions that had been necessary for the station's signal to reach viewers in areas with marginal reception.

TVS-Channel 4, one of four Brazilian stations owned by the SBT Network, broadcasts over an area of about 100 Km.

## WDZL-TV, Miami, On-Air With \$3 Million Equipment Buy

A new UHF station, WDZL-TV, is providing Miami, Florida viewers with an additional choice in television programming.

Ch. 39 went on-air with complete RCA transmitting and studio facilities valued at more than \$3 million. The new equipment complement includes: a TTU-110 110-kilowatt transmitter, a TFU-28DAS antenna, five

TR-800 one-inch video tape recorders, an HR-2 HAWKEYE studio video tape recorder, and HCR-1A HAWKEYE recording camera, two TK-761 studio/field cameras, a TK-29B broadcast telecine camera, two TP-66 16-mm telecine projectors, a TP-7 35-mm slide projector, a TP-55 multiplexer, and several switching systems.

## New WFSL-TV On-Air With RCA Transmission And Studio Systems

WFSL-TV, a new UHF television station in Lansing, Mich. is on-air with complete RCA transmission and studio facilities valued at more than \$2 million.

Owned and operated by F & S Communications-News Inc., Ch. 47 is the only independent station in the market, according to Tom Jones, General Manager.

The equipment complement includes a TTU-55C, 55 kW transmitter; TFU-25J pylon antenna; TK-44 cameras; quad VTR; two video switchers and a telecine system.

## New Transmission And Production Complement For WTXX-TV

The new owners of channel 20 in Waterbury, Conn. have improved the station's transmission and production capabilities with RCA equipment valued at more than \$2 million.

To enhance in-house productions at WTXX-TV (formerly WATR-TV), Channel 20 Enterprises Limited Partnership purchased two RCA TK-47 automatic studio cameras, three TH-200 one-inch video tape recorders with TBC's and a Grass Valley production switcher. For field production, a TK-86 portable camera and a TH-50 portable one-inch VTR were ordered.

The equipment order also included an RCA TFU-25G antenna, a TCR-100 video tape cartridge machine, two TK-29B telecine cameras, two TP-66 16-mm projectors, and two TP-7B 35-mm slide projectors.

According to Charles Allen, the station's Chief Engineer, the new antenna has improved signal reception for viewers as far away as Long Island, N.Y.

### Cap Cities' WTNH-TV Adds Automatic Cameras

WTNH-TV, New Haven, Conn., is enhancing its program origination and production capabilities with the addition of new automatic studio cameras and telecine equipment valued at approximately \$1 million.

One of six television stations owned by Capital Cities Communications, Inc., TV-8 will use three RCA TK-47B automatic cameras in a new studio scheduled to be in operation by mid 1983, according to Chief Engineer Larry Curtis.

The equipment order also included a complete telecine system comprised of RCA's new TK-290 automatic telecine camera; two TP-66 16mm projectors; a TP-55 multiplexer and a TP-7 35mm slide projector. The automatic TK-290 telecine camera and the TK-47 studio camera are companion systems, both automatically aligned by the same set-up terminal.

### Pro-Vision Productions Adds Four TR-800 VTR's

Pro-Vision Productions Inc., a full-service teleproduction facility in New York City, has enhanced its one-inch video tape editing capabilities with four RCA TR-800 video tape recorders.

The TR-800 recorders are integrated with a suite equipped with a computerized editing system, a digital video effects system and a character generator. Pro-Vision also offers on and off line editing for ¾-inch tape, and a 650-square foot studio equipped with wrap-around cyc, lighting grid and audio.

According to Gideon Fiat, Pro-Vision's Chief Operating Officer, improving the one-inch suite was necessary to accommodate the firm's growing clientele in industrial, commercial, network and cable television.

### Newsmaker In Brazil: HAWKEYE Recording Camera



RCA's HAWKEYE HCR-1 Recording Camera finds a newsworthy subject—Brazil's President, Joao Figueredo. The HAWKEYE system was demonstrated in conjunction with the 13th Congresso Brasileiro de Radifusao—Brazilian Broadcaster's Association—held at Brasilia, the nation's capital.

### Powerful New WVAH-TV On-Air With 5 Million Watts ERP

WVAH-TV (Ch. 23), serving Charleston-Huntington, W. Va., has begun broadcasting, following installation of a new RCA transmitter and antenna, and studio equipment.

The station, owned and operated by West Virginia Telecasting Inc., is the first commercial independent station in the Charleston-Huntington market. Authorized for five million watts of power, WVAH-TV (West Virginia Almost Heaven) is the state's most powerful station.

Valued at \$2.5 million, the equipment purchased by West Virginia Telecasting, included: an RCA TTU-110C 110-kilowatt transmitter, a TFU-28DAS antenna, a Grass Valley 1600-4S switcher, two TK-44 color television cameras, a TK-28A telecine camera, two TP-66, 16-mm telecine projectors, a TP-7, 35-mm slide projector, two TR-600 quadruplex video tape recorders, and a TCR-100 video tape cartridge machine.

The Ch. 23 transmitter/antenna site is atop Coal Mountain, near the station's studio in Winfield, W. Va. The antenna is mounted on a 1500 foot tower, notes Chief Engineer George Parnicza.

### Independent WFBT-TV, Minneapolis On-Air With RCA Package

WFBT-TV in Minneapolis, Minn. has initiated broadcasting with an RCA transmitter and antenna, and studio equipment valued at \$2.5 million.

Owned and operated by Channel 29 TV Inc. of Greenwood, Ind., the independent UHF station went on air with an RCA TTU-55C 55-kilowatt transmitter and a TFU-30JDAS antenna.

The equipment order also included five TK-761 studio/field cameras, four TH-200 one-inch video tape recorders, two switching systems, lighting equipment, microwave relay equipment, and a 7-meter satellite receiving station.

## HAWKEYE Systems Selected For VIP Coverage

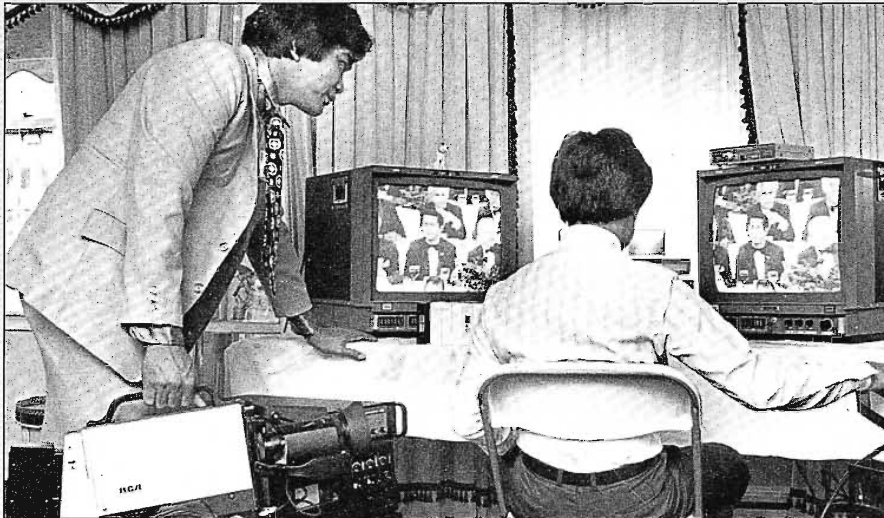

Full coverage of Philippines President Fernando E. Marcos' state visit to the United States in September 1982 was provided by the Maharlika Broadcasting System, using three complete RCA HAWKEYE recording camera systems and two editing facilities.

During stopovers in Washington, D. C., New York City, San Francisco and Los Angeles, hotel rooms quickly became editing suites to expedite the editing of tapes for satellite transmissions to the Philippines. Edited tapes were sent via UP/ITN satellite uplink to a receiving station at the Maharlika Broadcasting System Center in Quezon City, Philippines, which handled the recording and distribution of the transmissions.

The HAWKEYE systems included three HCR-1 Recording Cameras; seven HR-2 Studio VTR's, two HE-1 Edit Controllers and monitoring equipment.

## National Video Center Adds Three RCA TK-47B-EP Cameras

National Video Center, a teleproduction facility in New York City, has re-equipped one of its studios with three RCA TK-47B-EP extended performance cameras.

The extended performance model of the TK-47B automatic camera provides a higher signal-to-noise ratio, reduced geometric distortion and improved registration accuracy, among other factors designed to raise the camera's level of picture quality.

According to Herb Ohlandt, Vice President, Engineering, the new cameras have been a valued addition to National's production facilities and are heavily utilized. The automatic functions and fast set-ups of the TK-47 save time and thereby extend production capability, he adds.

## LeSea Broadcasting Co. Upgrades TV Stations

The LeSea Broadcasting Co. has purchased RCA transmitting equipment, video tape recorders and cameras valued at approximately \$2 million. The equipment package includes a new TTU-110C 110-kilowatt transmitter and a TFU-25G antenna for WHMB-TV (Ch. 40) in Indianapolis.

The new Ch. 40 transmitter provides a more powerful broadcast signal over a wider coverage area, according to Peter Sumrall, Vice President and Manager of Operations for LeSea Broadcasting.

Four RCA TR-800 one-inch VTR's are to be installed when WHME (Ch. 46) in South Bend expands its teleproduction facilities.

## RCA To Market Satellite Equipment

RCA's Commercial Communications Systems Division has announced a non-exclusive marketing agreement with SatCom Technologies, Inc., under which RCA's broadcast sales network will sell satellite earth stations provided by SatCom.

The agreement was announced by Joseph C. Volpe, RCA's Division Vice President for Broadcast Transmission Systems, and Marvin D. Shoemaker, President of SatCom Technologies.

Under the agreement RCA's domestic and international salesmen will market SatCom Technologies satellite ground station equipment to broadcasters and television program producers worldwide.

The agreement calls for SatCom Technologies, Inc., of Norcross, Ga. (a subsidiary of Radiation Systems, Inc., of Sterling, Va.) to provide high-speed, motorized 7 and 9.2-meter receiving dishes capable of meeting 2 degree satellite spacing requirements. The antennas incorporate the Model 4010 programmable controller with automatic scheduling feature. The 9.2-meter antenna has been approved by the FCC to serve as an "uplink" to send signals to a communications satellite.

Complete installation services for the SatCom equipment sold by RCA will be provided by Microdyne Corp. RCA will also offer satellite receiving dishes and antenna positioners manufactured by Microdyne.

"These agreements are in keeping with RCA's commitment to provide full-system requirements for broadcasters and television program producers," said Mr. Volpe.

# WISH-TV

## Automates Technical And Business Operations

In Indianapolis, Meridian Street is "broadcaster's row", dotted with television and radio stations and related businesses. Finding the Corinthian Broadcasting Company outlet—WISH-TV—is simplified by its distinctive architecture.

Characteristic of Corinthian stations, it features tall white columns in front, and wide expanses of glass, conveying an open look, even in its condensed urban setting. Behind the attrac-

tive facade is an equally impressive facility which is in the midst of an on-going renovation and upgrading program.

### **New Master Control Automation System**

WISH-TV has completed the installation of a total automation system, including business and technical operations. The most recent addition is a Master Control Automation™ system

supplied by Data Communications Corporation and now being marketed by RCA. It is integrated with that company's BIAS business automation system which has been in operation at TV-8 since 1973.

According to Chief Engineer John Demshock, the WISH-TV automation system is the first of its kind to be supplied from a single source, and is unique in that it provides total automation from order entry to billing, and all steps between, including switching and machine operations.

Mr. Demshock is a youthful veteran of Corinthian Broadcasting, coming to WISH-TV from WANE-TV, Ft. Wayne, Ind., where he was Chief Engineer. He began his career in the technical department at KHOU-TV, Houston, also a Corinthian station.



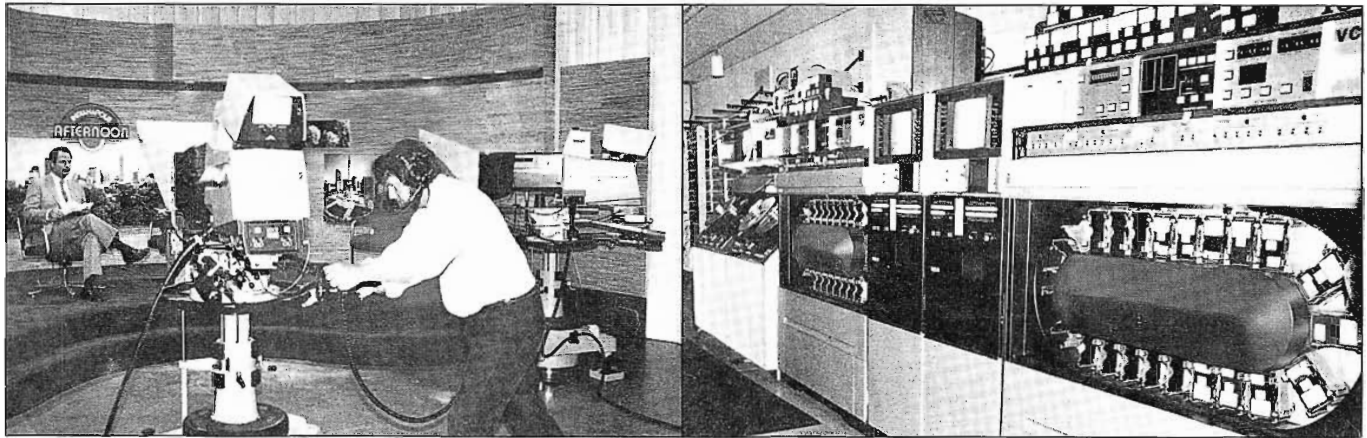

Automation systems at WISH-TV include four TK-47 automatic color cameras and two TCR-100A "cart" machines for automating commercial breaks.

## TK-47 Cameras and TCR-100's Fit Automation Plan

The move to total automation represents a logical extension of WISH-TV's trend in that direction in its technical operations. Even before the new Master Control Automation™ system was ordered, TV-8 was automated in their commercial playback system, with two TCR-100A video "cart" machines which are also an integral part of the new system. In addition, four TK-47 automatic color cameras are in use at the station for news production.

The TCR-100's and TK-47's were a part of major Corinthian Broadcasting purchases involving 24 TK-47 cameras and 10 "cart" machines for the group stations.

## "... Accomplish More With The Same People"

The technical automation system has been a remarkably effective addition to the TV-8 operation, Mr. Demshock affirms. It was readily accepted by the Master Control operators, who are very comfortable with the system, he adds. "The system permits accomplishing more with the same people. And, with the computer controlling switching, the transitions are smooth and the on-air look is

much cleaner."

The automation system is used by the Traffic and Program departments to generate the daily station log which lists all program elements and events including all video and audio sources. Even the transition wipes and dissolves are programmed into the log—which lists more than 500 events daily on average for WISH-TV's 21-hour broadcast day. An event is basically anything that involves the on-air switcher.

## Better On-Air Presentation

The log is available in Master Control both electronically as a CRT screen display, and as a printout copy. The MC operator checks the log and performs a line-by-line edit where necessary, making changes which are incorporated into the system via a keyboard located at the MC console. The most frequently required edits are for selecting the desired mix from event to event.

Included in the master control automation system is a separate microprocessor unit with floppy disc input which is located in the technical area. A second keyboard unit in Master Control is used in conjunction with this microprocessor for emergency operations if the

main computer goes down. This keyboard can be used to generate the complete event log, if necessary.

## Other MC Functions

After some initial concern, Master Control operators are pleased with the Master Control Automation™ system. They especially appreciate the fact that the computer-controlled operation makes for much smoother switching which results in a better on-air presentation. The system also has not dehumanized the job, since the operator is able to apply tech-

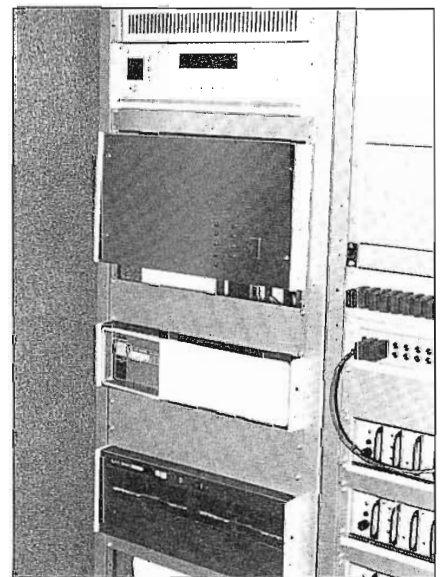

A separate microprocessor and floppy disk input for the automation system is installed in the technical area.





Daily station log generated by the Traffic and Program departments is checked and edited in Master Control which has its own keyboard and printer.

nical expertise in editing the log. And, when necessary, it is possible to over-ride the computer.

Even with the automation system handling switching functions, the MC operator has other duties, including verifying the event log, using the CRT display and a print-out "as run" record of each event as it occurs.

The MC operator is a member of the engineering staff and is also responsible for monitoring the transmitter remote control system and for handling video control for the four TK-47 cameras and two TK-27 telecine cameras.



On-location computer at WISH-TV is located in the Traffic department area.

## Media Pull Lists

The automation system has also simplified the task of loading the various sources in the sequence called for in the log. The operator used the keyboard to call for a "media pull list", which produces a print-out of the events listed for each source machine in the system. With this listing, seeing that the film, video and audio event sources are pulled from inventory and readied for airing is less tedious and time-consuming for the operators.

## Three Operating Modes

The WISH-TV automation system can operate in three modes:

1. *Absolute time*, which is clock or real time.
2. *Manual-Initiate* (handling the breaks inside a live newscast, for example).
3. *Estimated*. Computer automatically calculates upcoming times based on the duration of the current event.

Although the business computer operations are tied in with the BIAS central data processing system in Memphis, the Master Control Automation™ system has its own powerful computer on location in the WISH-TV Traffic Department. It is a Data General Eclipse computer with

192 megabytes of disk storage which is utilized for a number of functions, with more being added on a continuing basis.

Among the functions being handled by the on-site computer are: master control automation; word processing; General Ledger and Film Inventory.

## A Classic Film Data System

The film inventory and amortization function permits a wide choice of classifications in selecting films from the station's inventory. Films are classified by title, by star, by plot, and by distribution source as well as other categories.

The selected printout identifies the films involved in that particular category, how often and when they ran, their cost and amortization figures, as well as the rating and audience share for those which aired previously on network.

## Master Control Layout

Prior to installing the new automation system, the WISH technical center was rearranged and updated. With a new Grass Valley routing system installed for in-house distribution, a minimum of patching is required now, Mr. Demshock notes.

Master Control is a separate, glassed-in room, with doors on either end, permitting access

from the technical area and from the hallway near the Production Control room.

The Master Control console layout has the transmitter remote controls on the extreme right of the operator, then the MC automation system CRT displays, keyboards and monitoring facilities, and the on-air switcher (Grass Valley 1600-4S). To the left of the switcher is a custom-built machine control panel, and the four Remote Control Units for the TK-47 cameras.

The Set-Up Terminal for the TK-47 system is mounted just to the left of the RCU's for the two TK-27 telecine cameras.

On the extreme left of the console is a two-way radio base station and monitor/control equipment for the ENG microwave system. This position is manned by the Engineering Department to coordinate live remote microwave pick-ups during newscasts.

In Master Control, racks are easily accessible from the rear for maintenance, and the racks are cooled by ducting cold air in from the top. Four ducts are used, with cold air entering via the two inner ducts and exiting via the two outside returns. This cooling system has had a positive effect on operational life and reliability of the rack components, according to Mr. Demshock.

## Studio/Production Control

There are two studios at WISH-TV. The larger, Studio A, is 50' by 70' and is used for news programming, with several permanent sets in place. The smaller Studio B is used for a variety of productions. The TK-47 cameras are interchanged between the studios.

Since local news and programming as well as public

affairs fully utilize the studio facility, commercial productions are infrequent and not encouraged. At present, one production control room is used for both studios—a compact facility crammed with equipment.

The audio board is a custom stereo 36 channel system by ADM, with eight inputs per channel. Graphics are handled by a Chyron IV, a dual channel font-compose system with special effects capability. A TFS-121 Frame Synchronizer is used to genlock the incoming microwave transmissions from the remote mobile units. The production switcher is a Grass Valley 1600-7K.

For news production, four positions are manned: Producer, Director, Graphics and Audio. In addition, as noted previously, an Engineering department staffer is in Master Control at the microwave monitor position.

## TK-47's . . . "Best Video In Town"

Three of WISH-TV's four TK-47 cameras are used in

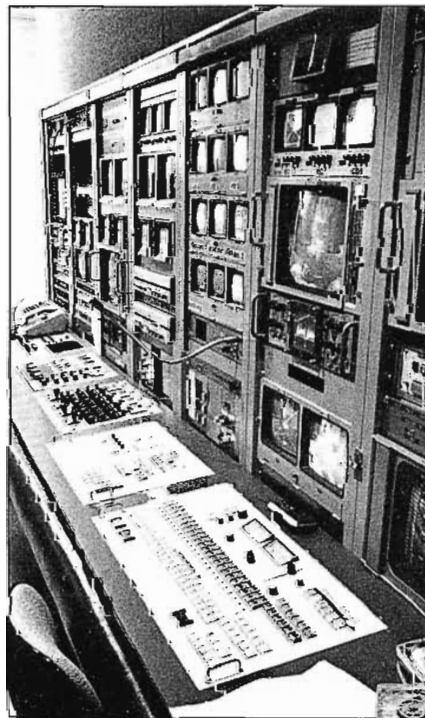

Master Control provides a full range of control functions.

Studio A for news production, and all are equipped with prompters. The TK-47's have been an excellent addition to the station's technical facilities, Mr. Demshock remarks. They are so stable, he says, that even the "auto" check function is only used as needed. The cameras are usually operated with auto iris.

"With the TK-47's, we have the best video in town, and the automatic set-up provides an additional advantage of assuring near-perfect matching of the cameras."

With the stability of the TK-47 cameras, the automatic check is useful, but not critical at this time, Mr. Demshock reports. However, as components age from years of service, stability could be affected, requiring more frequent adjustments. When this happens, the automatic check and set-up capability will be even more useful and cost effective, he notes.

The File and Recall facility on the TK-47 is used to file each set-up, providing the check mark

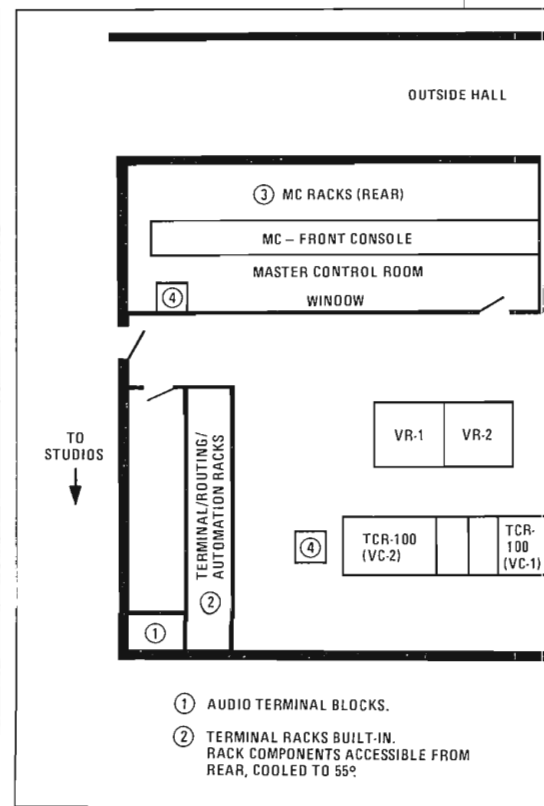

for the next set-up to determine whether any corrections are needed. File and Recall are also used to compensate between lighting differences in Studio A and B.

## Cost-Effective TCR-100's

Even before the master control automation system was operational, the two TCR-100A video "cart" machines provided a high degree of automation, in handling commercial blocks.

They have been very cost effective, Mr. Demshock says, performing reliably and requiring little downtime. The on-air color quality of the "carts" is uniformly excellent, he adds.

The TCR's at WISH-TV have separate Signal Processing Units for stand-alone operation, and do not share electronics with the other VTR's in the system. However, John Demshock points out, the electronics for the TCR-100's and the two TR-600 quad VTR's are from the same family, which is a maintenance convenience.

## All Commercials Dubbed To "Cart"

The two TCR-100's in the system are identified as "VC-1" and "VC-2". In the system, the "VC-2" is used for airing commercials, while "VC-1" handles dubbing and production functions. The "cart" machines handle about 400 on-air plays per day. In addition to commercials, they are also used for news blocks, for playback of pre-recorded news stories, and for assembly operations involving standard openings, closings and transitions during segments of the news program.

At TV-8, all film and tape commercials as well as ID's, PSA's, etc. are dubbed to cart. The station has an inventory of about 2300 carts.

With the new automation system on-line, "tags" are frequently programmed in by the computer rather than requiring a separate dub on the "cart" machine.

In the unlikely event of a failure in the on-air TCR, the Master Control operator can advise the computer to change log events to the second TCR, without requiring line-by-line corrections on the "upcoming events" monitor display.

## Maintenance Efficiency A "Must"

TV-8 operates with a lean technical staff comprised of eight operators and three maintenance technicians.

Engineering is responsible for all maintenance at the studio and transmitter site and for manning the Master Control, tape and telecine facilities. Production provides staffing for Audio, Switching, Graphics and camera operations.

Maintenance is organized for efficiency. Preventive maintenance is scheduled for key equipment such as TCR-100's, cameras, transmitter and micro-

wave mobile units. For handling other maintenance, especially those involving equipment breakdowns, a three-part snap set maintenance form has proven effective. The form is originated by anyone noting a problem. The equipment item and the apparent problem are identified on the form. One copy stays with the defective equipment; one copy goes to engineer for follow-up, and one copy stays with the originator. The engineering copy includes the listing of the apparent defect as well as the repairs/solution and is kept in file. A separate file record is kept for each individual piece of equipment, providing a history of maintenance.

This is especially important for Corinthian Broadcasting, John Demshock notes, since equipment is occasionally exchanged with other stations in the group. The maintenance data bank can also be stored as a function of the total automation system.

A complete camera set-up check is made weekly on each of the TK-47's. The master control automation system can also be programmed to initiate camera checks at any time. However, Mr. Demshock notes, this function has not been incorporated at this time. Further, he adds, the TK-47's are so stable that he rarely finds it necessary to make daily checks on the cameras.

## Automation . . . An On-Going Process For WISH-TV

With their automated business and machine control systems in place, the WISH-TV staff is finding new applications for expanding the capabilities of the system. For them, automation is an on-going process of becoming, never a static state of being.

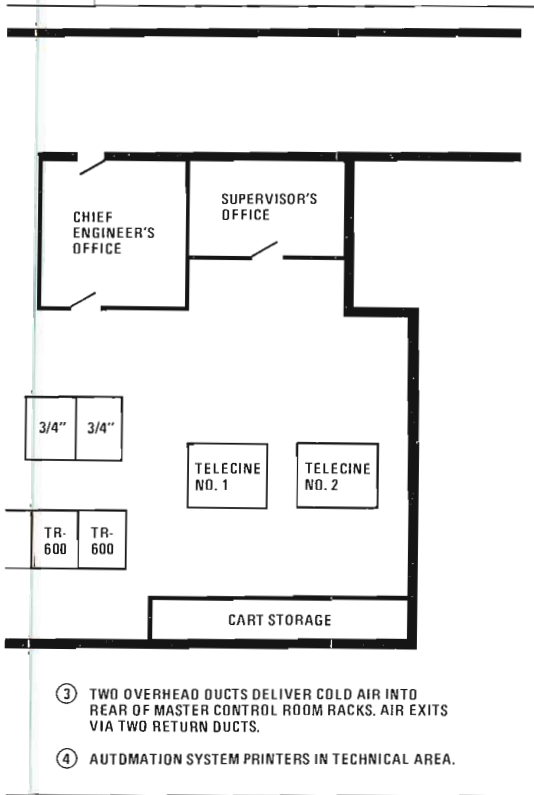

# ON THE NEWSFRONT

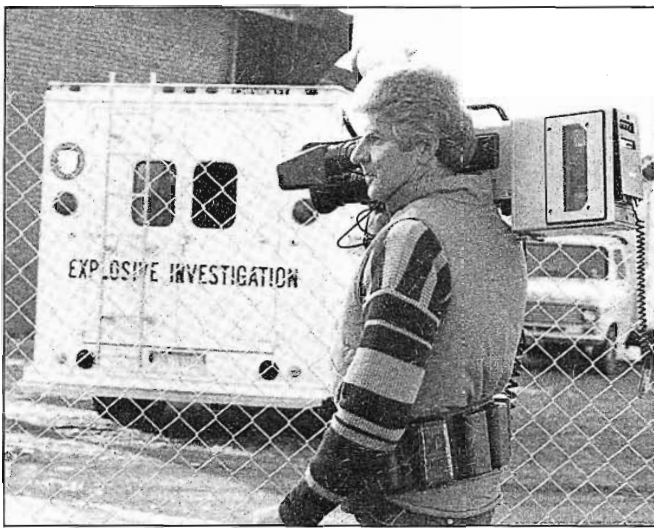

WKBD's Tom Bradley: "on the scene faster".

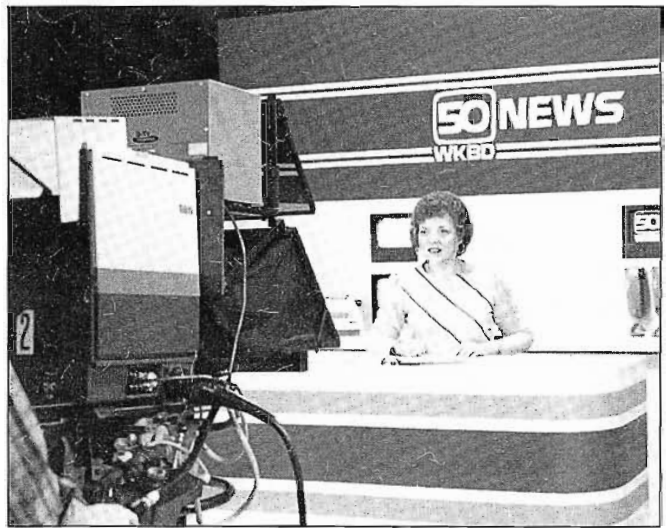

HAWKEYE local news coverage effectively augments studio reports.

On October 4, 1982 WKBD-TV in Detroit (Mkt. 7) expanded its news operation with the addition of CNN Headline News and locally originated news produced with its own crew and newly purchased ENG gear.

WKBD was joined by its sister independent stations—WFLD-TV in Chicago (Mkt. 3), WKBS-TV in Philadelphia (Mkt. 4), and WLVI-TV in Boston (Mkt. 6)—as all four stations carried their own local inserts within a prime time telecast of CNN Headline News.

In expanding the news, these stations were also making a pioneering step forward. For with their first local newscasts, they became the first stations in the world fully equipped in the new ½-inch broadcast technology to air news gathered and edited in that technology.

## The Best Approach

Al Martin, director of engineering, Field Communications Corporation, and engineering manager of WKBD explains the thinking behind the decision to break with tradition.

"Field (the stations' ownership) chose the CNN format because it was a very flexible programming tool. It provides viewers with national and international news, allowing us to concentrate our efforts on local news coverage. It made news expansion easier and more affordable."

Martin says that he and his group of station engineering managers sought similar facility and affordability in ENG equipment—"a field system compact enough for easy adaptation to a one-man

crew."

Martin continues, "Since we were starting from scratch with street reporting, there was no reason to take a lateral step into the ¾-inch format. A step down to a one-tube recording camera wasn't acceptable either. We were striving for an improvement over traditional picture quality in news. The HAWKEYE recording camera system fulfilled our needs from a human load standpoint, in video quality and it was ready when we were."

Glenn Romsos, engineering manager WKBS in Philadelphia, asserts, "It was the best approach."

## The Equipment Base

Each station is equipped with the HCR-1 recording camera. A completely self-contained unit, it weighs just 24.6 pounds including camera, recorder, lens, viewfinder, microphone, cassette and battery.

The 10.5 pound camera employs three ½-inch high-performance Saticon tubes. It features a self-contained viewfinder with full metering indicators, +9, +18 dB gain, comet tail suppression, contrast compression and other conveniences currently in demand. The nine-pound recorder uses a three-track recording system called ChromaTrak. Y (luminance), I, and Q (chrominance) information is recorded on separate video tracks by means of two pairs of video heads. There are two audio tracks, a control track, and a time code track fed by an internal SMPTE/EBU time code generator. Twenty minutes of recording time is provided with each T-120 VHS cassette. Adaptors are on order which allow the two units to function separately

## Four Top Market Stations Expand Their News With A Pioneering Step Forward

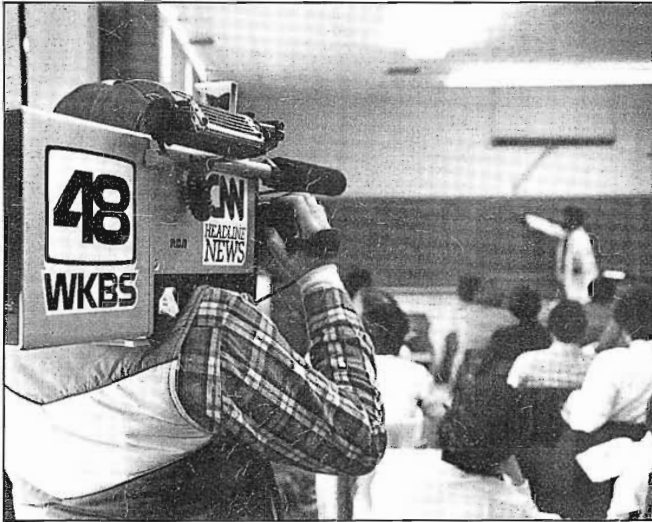

In Philadelphia: transition from film made easy.



Joe Danner covers Cheryl Nathans' report at murder scene.

and/or work with other cameras and recorders.

In the studio, each station has two HAWKEYE HR-2 edit recorders. Each has search modes up to 8 times normal and allows Y, I/Q and/or NTSC inputs and outputs. These are interfaced to the HE-1 edit controller allowing simple frame by frame edits. Through Y, I, Q component editing, the stations are able to obtain the full benefit of the superior video output of the ChromaTrak format, particularly advantageous in multiple generation post-production operations.

### The Daily News

Three times a day Monday through Friday, WKBD carries the CNN Headline News Service—½ hour programs at 5:30 A.M. and 11:30 A.M., an hour at 10-11 P.M. Saturday and Sunday the station carries CNN in the evenings. Although times vary, the format is the same for its sister stations.

Greg Neubacher, news producer at WKBD, puts the station's news production into perspective, "We carry about 10 minutes of locally originated news weeknights within the CNN telecast. Trying to compete with the network affiliates which cover just about every news event is senseless. We have one camera-recorder on the street, so we must be selective. We try to do some creative things—stories that attract interest, that people care about—in addition to providing the information our viewers must have."

Considering the station's limited resources, "WKBD is doing well" in Neubacher's estimation, covering 6 to 8 stories per newscast. Applicable stories from the previous day open an A.M. news

and public affairs show called "Morning Break".

The station is experimenting with crew deployment. Usually, one operator is on the street for eight hours a day, sometimes with a reporter, sometimes gathering file footage for later airing. Often the same technician edits the stories. Other times, another technician will work with the reporter in the editing suite.

And so it goes in Philadelphia, Chicago and Boston.

All four stations edit in ChromaTrak format. Each of the editing systems are equipped with ADDA AC-20 dual time base correctors. Dwain Schoonover, engineering manager of WFLD in Chicago, explains how his station goes directly to air from the ½-inch editing decks. "The ADDA has the capability of doing an assembly set—like a push-on, push-off or wipe between the two decks. So, you don't have to lose a generation by transferring to another format."

Philadelphia and Boston have taken the route of WKBD in Detroit, transferring edited stories to TCR-100 carts. News producer Greg Neubacher explains, "The basic format of our newscast is to duplicate the CNN graphics presentation. The drop shadows, the boxes, etc. are set-up on our 1-inch machine. We do a mixed effects bank, keying the ½-inch material over the CNN background on 1-inch and transferring directly to the TCR-100 carts." Adds WKBS engineering Glenn Romsos, "The TCR carts are used solely for ease of operation. If our commentator reads a story too fast, we can dump the excess video faster."



**Bradley on HAWKEYE: "the only way to go".**  
**Bradley and reporter Margo Williams at union picketing.**  
**Bradley mixes Williams' voice over with his 1/2-inch video edit.**

## Operations Satisfaction

"Everything has been going just fine here at the Detroit station. We haven't had any serious problems to speak of at all," says engineering manager Al Martin of the HAWKEYE system. He adds, "Our operators like the system very much."

Tom Bradley, a 22-year veteran cameraman, exudes enthusiasm when he talks about his role as WKBD's "one-man band" ENG operator. "I find the HAWKEYE recording camera great, really. I love it! We've used it under varying conditions of shooting—with lights, without lights, in cold and rainy weather. Handling is good—it's well balanced. Operation is easy. We've been using it for about two months now and it's putting out some great video."

Bradley uses a tripod mount for press conferences, but says he's done more handhelds. The length of the HCR-1 is of no real consequence, Bradley remarks. "Once you remember you have a bit of backend sticking out there, it becomes second nature." He adds, "There are other systems lighter and more compact. But, HAWKEYE doesn't weigh much more than a TK-76. I have no problem shouldering it for a long period of time. In fact the weight of the system gives you just enough bulk for nice steady pans and tilts. In a lightweight camera, you can't get that nice smooth movement."

The HCR-1 is simple to operate asserts Bradley. "Camera controls are at easy access. With the tape controls at the back, you load up before you go into a situation, then use the front controls to start and stop. The viewfinder makes it easy to compose the picture. It seems to be really clear, with good centering. The LED indicators make it easy to keep track of everything. I keep them on all the time. I leave the shotgun mike on while our reporter uses a stick mike on channel two."

In his final analysis of the HCR-1, Bradley concludes, "This system is proving out to be very good. It is well designed. That's what all the camera people say. Whenever I go out, the other newspeople in town have to try it. They gather 'round—because they know it's coming. I figure if you are going to be a one-man crew, it's the only way to go."

News producer Greg Neubacher recalls, "The one thing I really liked was in the editing system. We uncrated it and set it up—all the color phases were dead center. Everything was perfect. I mean it was unbelievable! After all the shipping and handling, the equipment set-up with zero problems—zero!" He continues, "We've interfaced the system with a little audio mixer. We go to air with the audio mixed exactly as we want it, so we

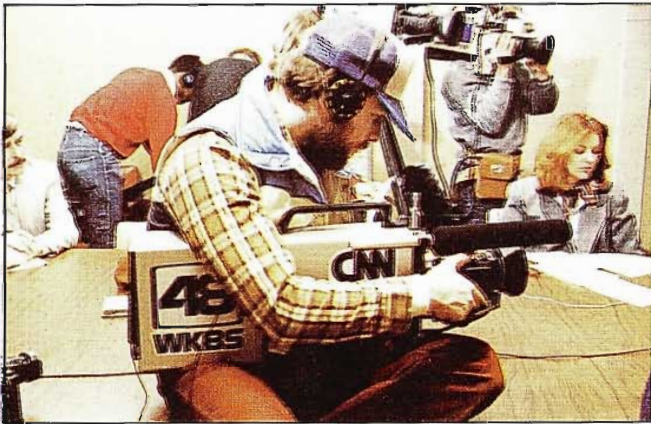

**Danner on HAWKEYE: "easy to operate".**  
**Prime position for Danner at press conference.**  
**Danner and Nathans editing dailies in 1/2-inch.**

don't have to ride audio on the air."

Editors at the Chicago station like the HAWKEYE editing system reports Dwain Schoonover, engineer manager. "It's faster than the 3/4-inch equipment we have here. Tape handling is faster. It locks-up and shuttles faster. You can find your edit points much more quickly."

### No Video Background

Operators in Philadelphia have had news experience, but in film. WKBS engineering manager Glenn Romsos reports, "It's been quite an adjustment. We had little time to train our operators before they hit the street. But, they do like the HAWKEYE and feel it's easy to operate. Things are coming along quite nicely."

"My real problem is getting the unit in here long enough to make the proper adjustments. It's always on the street. Still, it's holding up rather well," he says approvingly. "Electronic editing was a new experience. But, the HAWKEYE editing system is rather simple and straight-forward. Our technicians caught on quickly and haven't had any problems whatsoever."

### Final Assessment

Detroit's Al Martin who spearheaded the technical aspects of Field's expansion of news recalls, "We had a little over four months to set-up satellite

feeds for the CNN program and equip our stations for news origination. It was a fairly complicated project. But, we hit our air date with few technical difficulties."

Field stations had just two weeks for HAWKEYE system set-up and crew training prior to going on-air. Martin reports, "Things have run quite smoothly, considering. Oh, there's been the routine technical problems normally expected with a new product. But, service from the RCA product support group has been excellent."

Assessing HAWKEYE picture quality Martin notes, "We have an excellent on-air quality for news. If I look at news story A on our station and the same story on a local VHF station, produced in the 3/4-inch format, many times our quality exceeds their's. I'm sure the difference is inherent to the tape machine."

Reports from other stations are similar. Dwain Schoonover at WFLD says, "Our back-up is the 3/4-inch format. Video quality in the ChromaTrak format is much better."

Glenn Romsos of WKBS explains, "3/4-inch is laced with problems. It's a color under system. In the dubbing process you're faced with color delay and all the limitations inherent to the format. The ChromaTrak format is far superior. I've compared some of our better news footage with the other

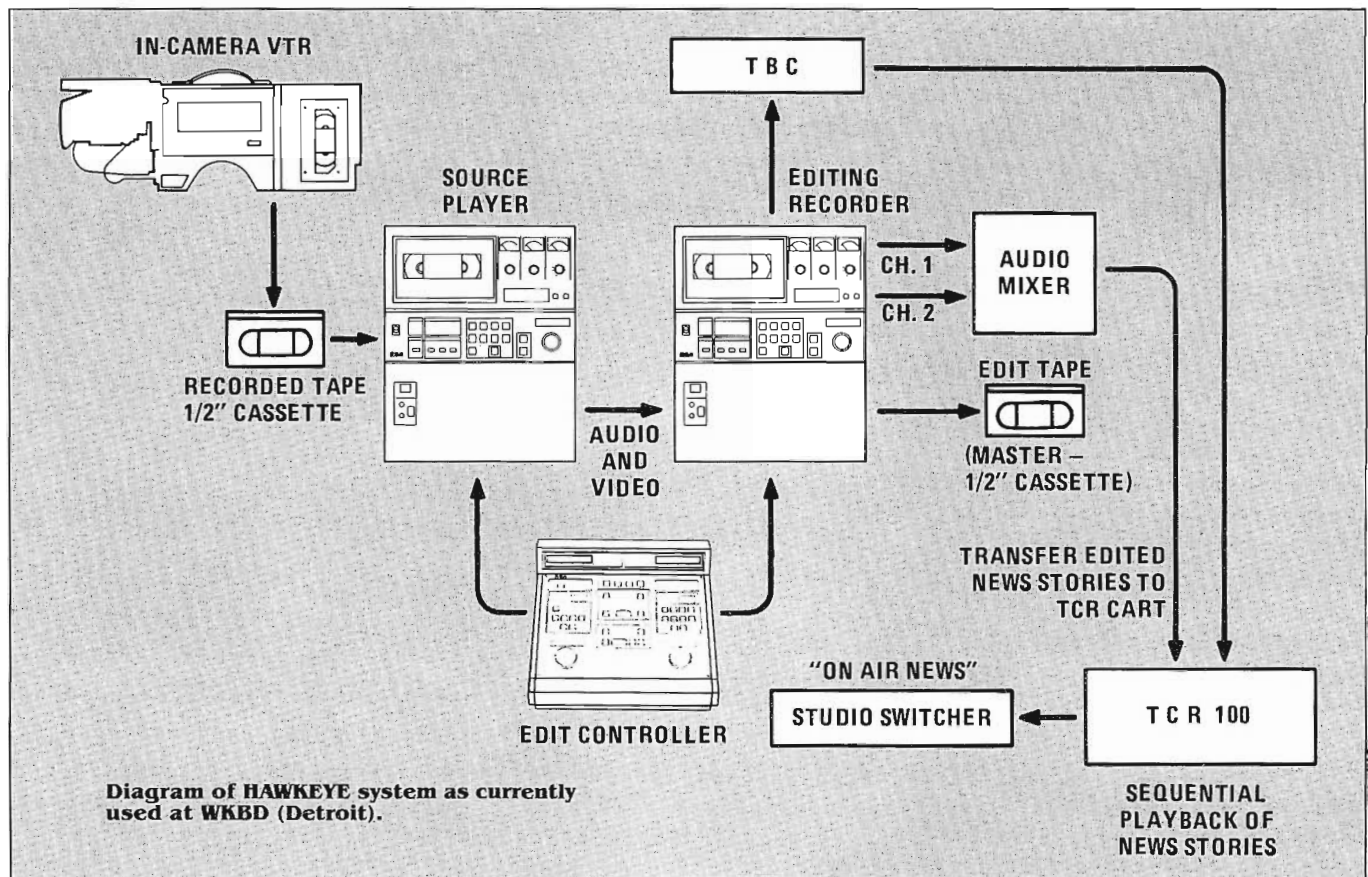

local station's coverage of the same story—and the difference in quality is incredible."

Part of the secret of HAWKEYE picture quality is the ChromaTrak format's Y, I, Q component system of recording. Color and luminance signals are recorded on two completely independent tracks, thereby yielding 360 lines of horizontal resolution, compared to 260 lines in the 3/4-inch format. Furthermore, the color signal is recorded without the use of a color subcarrier—an innovation which makes color editing as simple as monochrome editing, and ends the "jump left" or "jump right" of a poorly-made color edit.

These differences make the system easily adaptable to commercial production notes Romsos. As he recalls, that capability was one of the decisive factors in making the HAWKEYE system choice. He says that it's part of an overall plan to take commercial production head on in the future. "The HAWKEYE system would offer an affordable alternative to 1-inch production for clients." His station recently shot several contests held by Toys "Я" Us. "The results were phenomenal. Very, very good quality video," Romsos adds.

At WKBD, the HAWKEYE system has been used for promotional pieces and for taped interviews of Red Wing Hockey fans, players, coaches, and managers which run during breaks in hockey telecasts. Greg Neubacher reports, "Our production people

are happy with the quality of the visuals and the versatility of the system." With years of teleproduction experience Neubacher concludes, "For the independent producer, for smaller production houses, this is a good system. In many cases, it is a far better, cost efficient production system than 1-inch."

At Field stations the HAWKEYE is being put to the test in every way conceivably beneficial to operations success. But, for the time being, the concentrated effort is in the realm of news. With just a few months in operation, it is a bit early to measure the success of news efforts, although all of the stations have reported positive signs of viewership response.

One thing is for sure, the concept of the "one-man band" is proving to be easy and affordable. WKBD has already found it possible to add a second local newscast to the mid-day CNN program within their originally defined budget. It seems with expanded news programming, and a pioneering step forward into 1/2-inch HAWKEYE technology, the stations have made the right moves take them full speed ahead into the future of news.

In addition to the Field Communications stations mentioned above, Field also operates KBHK-TV in San Francisco.



# Mississippi ETV

## Cuts High-Quality Production Costs To Bring A State Home To Its People



HAWKEYE: the key.

For nearly a year now, Jackson-based Mississippi ETV has been traveling the backroads of Mississippi searching out the ordinary people and extraordinary people of the state and recording their lives at work, at play and in the intimacy of their homes. The result is a real people series called "Mississippi Roads" which reflects the character, vitality, beauty and variety of the state.

The series was an ambitious project from the start, but one METV has carried off with imagination and style. A magazine formatted series, "Roads" is more documentary in approach. It has no host. Segments of each show are held together by the personalities of its people. Yet, even more important to the working success of the project, say station personnel, are the high video quality and major cost savings that have been realized with the use of the HAWKEYE HCR-1 recording camera and HR-2 studio VTR.

### Meeting Quality Standards

"We couldn't have done the series without HAWKEYE," asserts Larry Holden, METV's Director of Production. "We are a production house long before we are a TV station. We produce high quality crafted productions. It demands a great deal more care in shooting and editing, and often requires multiple generations in the editing process."

Until HAWKEYE, Holden says he wouldn't have considered anything but 1-inch to handle in-field recording. "We've been very pleased with HAWKEYE system performance. We're getting top-of-the-line video quality out of the camera. Pictures from the recorder are really impressive. The 1/2-inch ChromaTrak format is giving 1-inch a close run for its money."

Dave Wilson, METV's Director of Engineering, reports, "Our decision to purchase HAWKEYE for this series was grounded in our belief that it not only met our video standards, but that the HCR-1 was simple enough and reliable enough to go on location without a technician." Historically, the maintenance technician had been a necessary factor for station remotes.

### Reliability Cuts Costs

Since July, when shooting on the series began, the HCR-1 recording camera has been the sole production system of a one-man equipment crew and a producer. HCR-1 reliability has successfully eliminated the need for field maintenance, saving valuable time and dramatically cutting costs.

Out four days per week, "Roads" two-man production staff returns to the station every Friday to drop off tapes and to checkout the recording camera. Dave Wilson reports, "Registration has held up very well. The

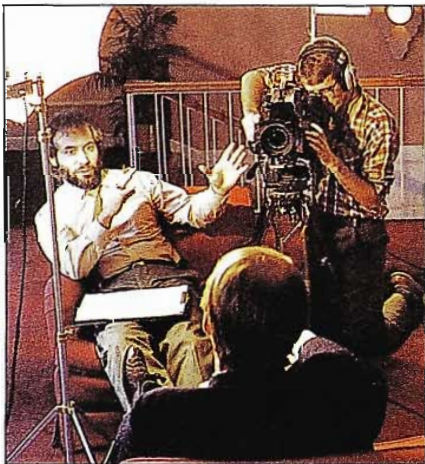
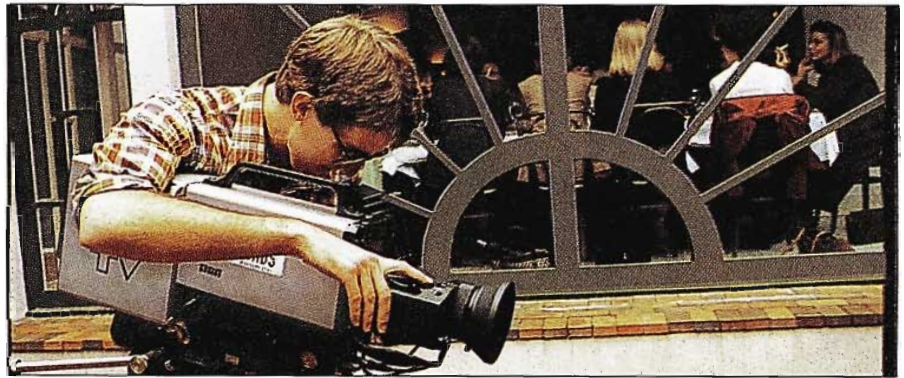
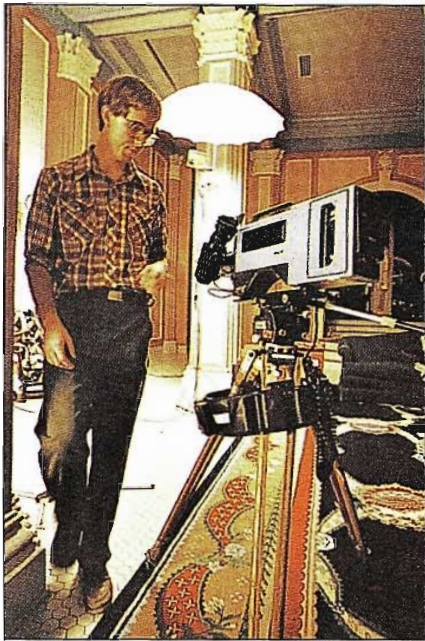

## 25 Set-Ups In 12 Hours

camera has proven to be very stable. We've had absolutely no problems with the recorder. It has been extremely reliable."

Larry Holden adds, "HAWKEYE's been sprayed with salt water and heaved up and down on a 30-foot sailboat in the Gulf. We've shot out of race cars at high speeds without gyroscopic errors. We haven't taken any special precautions to protect it against dust, rain or RF; and yet, we've never been presented with any special problems due to the various environmental conditions encountered." He continues, "To my knowledge there's been absolutely no downtime. That alone has put us under budget."

### Film-Style Shooting Cuts Costs, Enhances Series

Rick Klein, one of the show's three producers, says he's really pleased with the quality of video he's getting and with the convenience and creative flexibility film-style shooting gives him in the field. "My videographer can set up faster; we cover more ground more quickly, so we're saving production dollars. We have the freedom to shoot in the style we find most appropriate, because we're on our own. But, most importantly, we're finding people who are not used to being on TV can relax and be themselves."

That latter advantage is what Holden sees as the one-

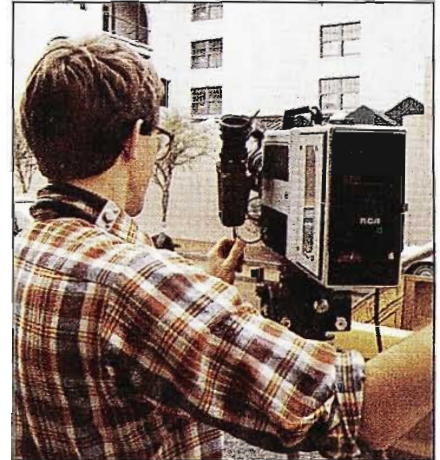
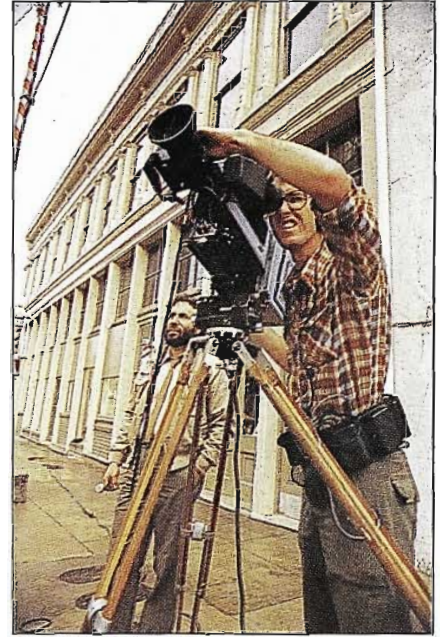

**HAWKEYE breaks the time barrier of one-man production: Videographer Ken Bowlds shot 25 set-ups in 12 hours to complete the episode on the Natchez Eola Hotel restoration for Mississippi ETV's new documentary series "Mississippi Roads".**

piece HCR-1's best advantage. "The HAWK is so much less intrusive. People lose their fixation with the equipment and trappings of TV." It is then, he explains, when you can capture the joy of a closed society of sacred singers as they celebrate their private rituals, the pride of an American Indian shining through a tribal ceremony otherwise closed to outsiders, the dignity of a timid, aged woman as she recalls her life in the oldest incorporated black community in the nation. "When HAWKEYE becomes a participant rather than an intruder that's special," concludes Holden, "because that is when people really open up to you."

In mid-January, "Mississippi Roads" went on air. Across the state, Mississippians were given a rare glimpse into the lives of their own folk, the hearts and minds of their own heritage.

Meanwhile, Mississippi ETV has already begun planning their second experiment in HAWKEYE remote production—an instructional TV series called "About Mississippi"—a series made possible in large part by the cost-effective benefits and high video quality of the HAWKEYE recording camera system.

# ON-LOCATION WITH TK-47 AUTOMATICS

From its inception, there was never a question that the TK-47 Automatic Camera would find its place in television studios, where its fast set-ups, automated functions and superior performance features would result in expanded production capability with superb picture quality.

Unsurprisingly, the TK-47 is equally popular as an on-location camera—for the same reasons. Scores of TK-47 automatics in the field have proven to be extremely reliable, durable per-

formers. Operational simplicity, rapid set-up, stability and triax/multicore capability enhance their cost effectiveness as a field camera.

In the field and in the studio more than 500 TK-47 Automatic cameras are delivering consistently outstanding picture quality.

This capsule report covers several tele-producers and broadcasters who are making extensive use of TK-47s for handling a diversity of remote productions.

## TPC AND TAV COVER ASPEN'S SLOPES WITH TK-47s

Covering ski slope action is a pressure assignment for cameras and operators. At the 1982 Aspen Winter National Skiing Championship competition, a battery of TK-47 cameras easily handled the pressure—covering the event for Trans-World International.

Two top-tier teleproduction firms—TPC Communications of Sewickley, Pennsylvania and Trans-American Video of Las Vegas—combined forces for this rigorous 13-camera shoot which involved nine TK-47s.

In addition to TPC's five TK-47T triax cameras with cable runs of up to 13,000 feet, four TAV TK-47s were deployed on the slopes.

With their automatic set-up, stability and superb picture quality, TK-47s are especially popular for handling on-location remotes.

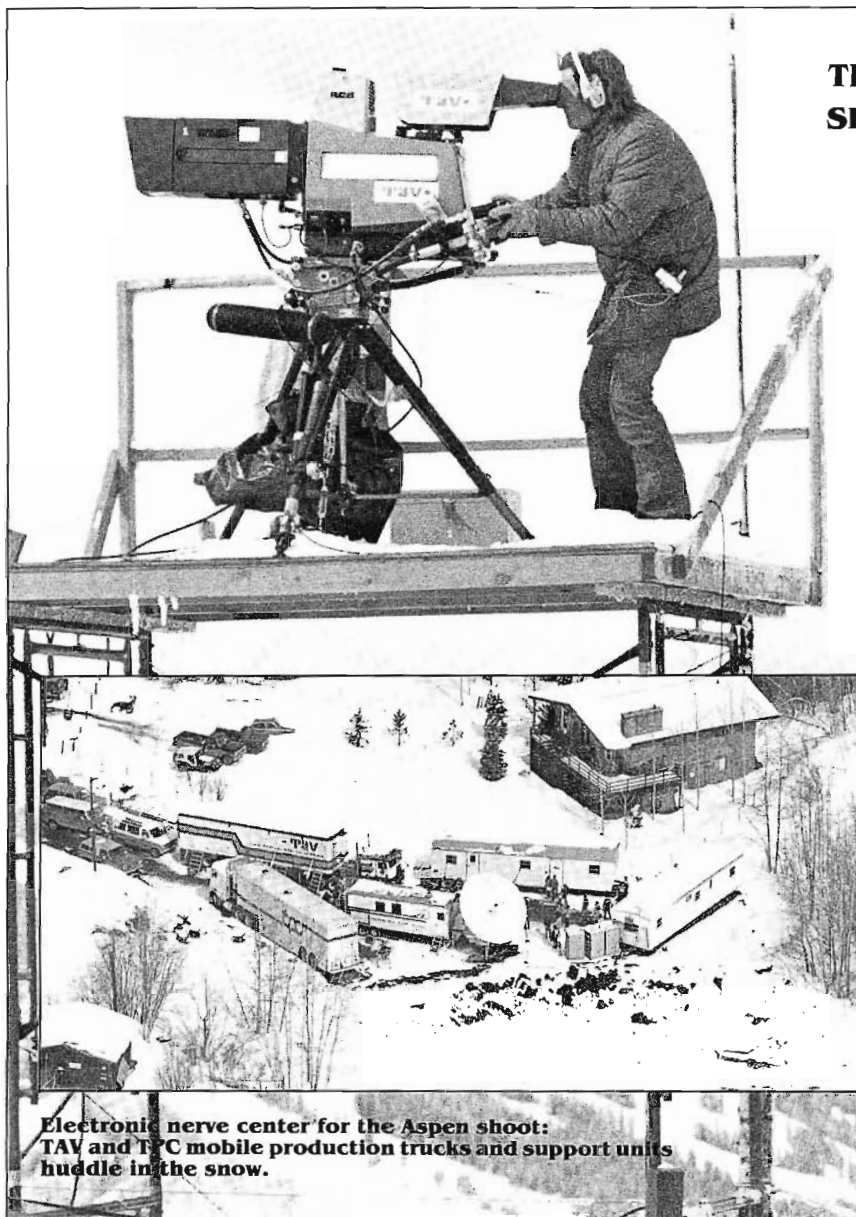

**Electronic nerve center for the Aspen shoot:  
TAV and TPC mobile production trucks and support units  
huddle in the snow.**

## Tel-Fax Speeds Set-Up with TK-47 Cameras for "On-the-Go" Sports Production

"Cover a Saturday night football game in Austin. Swing over to Dallas for a college tennis match on Sunday afternoon. Then get set-up at Arlington Stadium to cover the Texas Rangers' final season baseball series with the California Angels starting on Monday night."

That's the kind of challenging schedule facing Tel-Fax, a mobile production facility operating out of Arlington, Texas and Bath, Pennsylvania. It is being easily solved in large part thanks to the help of four TK-47T automatic television cameras. According to Tony Symanovich, Vice President of Tel-Fax, the cameras are drastically slashing set-up time and costs.

### Ready to go With Pushbutton Speed

"We're able to get into a sports facility and get ready so much faster with our 47s. Once the cameras are in position and powered up, with the automatics it takes only a few minutes to do the electronic set-up from the production unit. Because of that, we can schedule much tighter move-in times—and the TK-47 pictures are just fantastic."

### Complete Mobile Facility

Tel-Fax operates a 35' mobile unit from the

Arlington facility. On board equipment includes two TH-200 1" video tape recorders for capturing game highlights and instant replays. Graphics generation, audio, production, and complete video control—featuring the TK-47 auto set-up terminal—round out the truck's equipment complement.

At a University of Texas football game, a second smaller van was equipped with two TH-50 VTRs for recording the entire game for delayed airing over cable systems in the Southwest.

In addition to the four TK-47 triax cameras, Tel-Fax also utilized a platform-mounted TK-76 on the rear of a pick-up truck to catch sideline action.

### Have Cameras, Will Travel

With a heavy concentration of sporting events, Tel-Fax mobile units provide coverage of Buffalo Sabres hockey, Texas Ranger baseball, and professional and college events of every variety. Conventions, concerts and special events round out their production schedule.

The company presently has two vans in operation, and is planning the addition of a third unit in the near future.



**Cameraman Phil Crow catches game action with TK-47T. Note local news teams in press row with their TK-76 cameras.**

**Inside mobile unit, video operator Tom Michener has total operational control of four cameras from full function RCUs. Large panel in rack at right is automatic set-up terminal for all cameras.**

**Announcers Steve Ross and Merle Harmon record pre-game comments.**

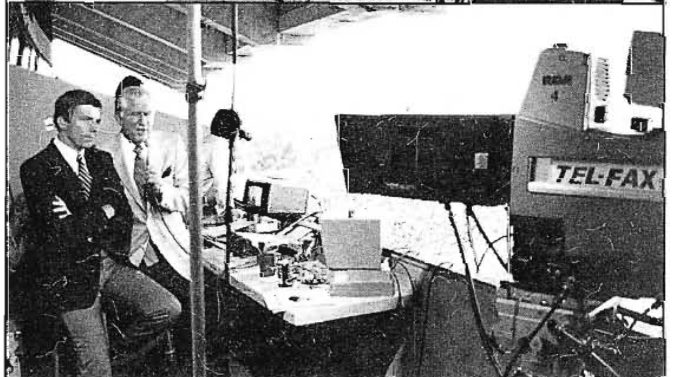

## E. J. STEWART'S "TRAVELING SHOW"

E. J. Stewart's two "Gemini" mobile television production vans ride with a full complement of high performance equipment to meet a heavy shooting schedule.

Four RCA TK-47 triax cameras match the demanding operating requirements perfectly providing fast set-up, reliable performance and excellent picture quality. Only four days after delivery to the company's Primos, Pennsylvania headquarters, the cameras hit the road, covering a series of critical back-to-back remote assignments.

How was Stewart able to ready their new cameras to meet this tight schedule? Steve Kurtz, Remote Operations Engineer explains: "RCA sent a TK-47 Triax Camera specialist on the road with us to help bring our new cameras on-line in time for the first shoot—a Charlotte, NC auto

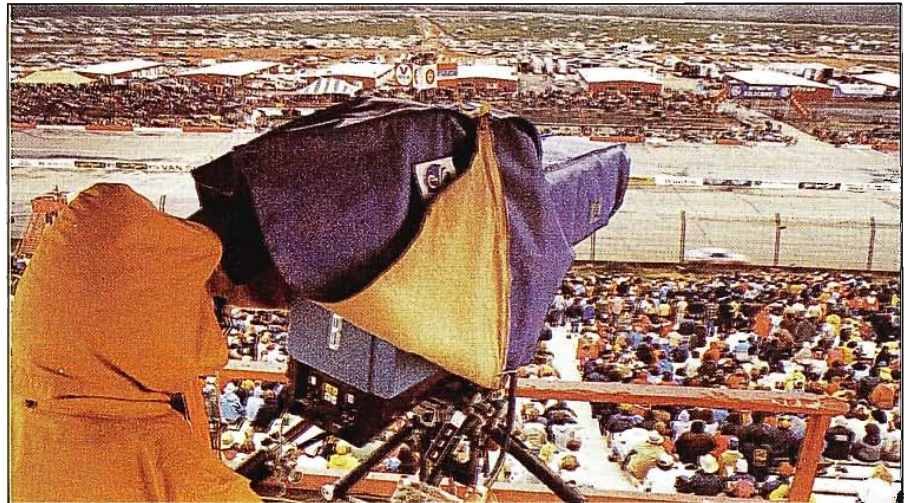
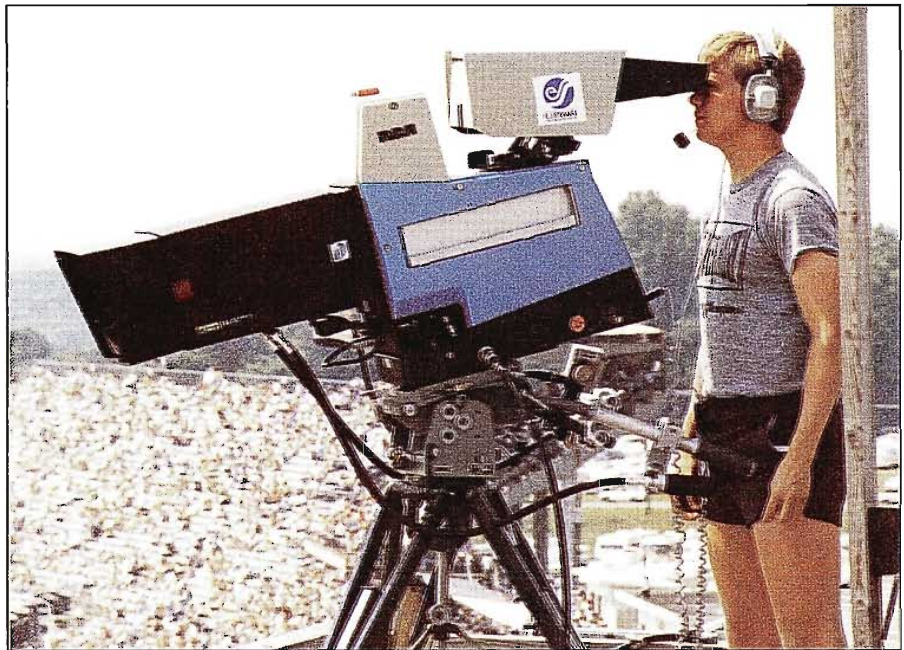

**Four Days After Delivery (top left)**  
In Charlotte, N.C. TK-47s cover "Mountain Dew 300" and "World 600" NASCAR races with Mizlou TV network at the production helm.

**Five Days After Delivery (top right)**  
From the White House Library, Stewart airs President Reagan's European address via satellite with their new 47s.

**Eleven Days After Delivery**  
In the Pennsylvania Poconos, TK-47s pick up the action of the "Van Scoy 500" NASCAR face for Mizlou.

For this shoot, Stewart put the new HAWKEYE system through a heavy-duty performance test.

TK-76 and TK-86 ENG cameras provided additional closeup coverage of the action.



## FEATURES TRIAX TK-47s

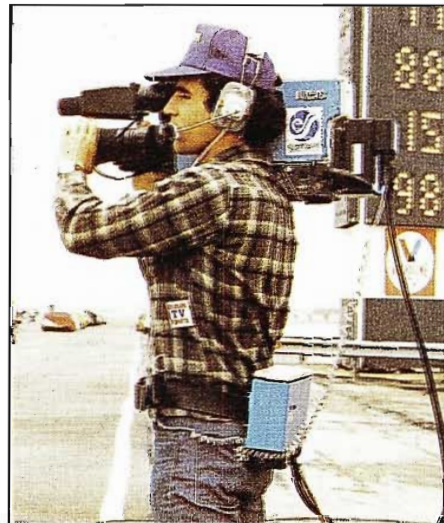
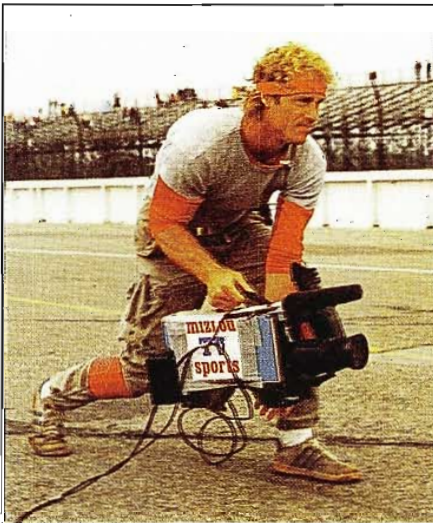
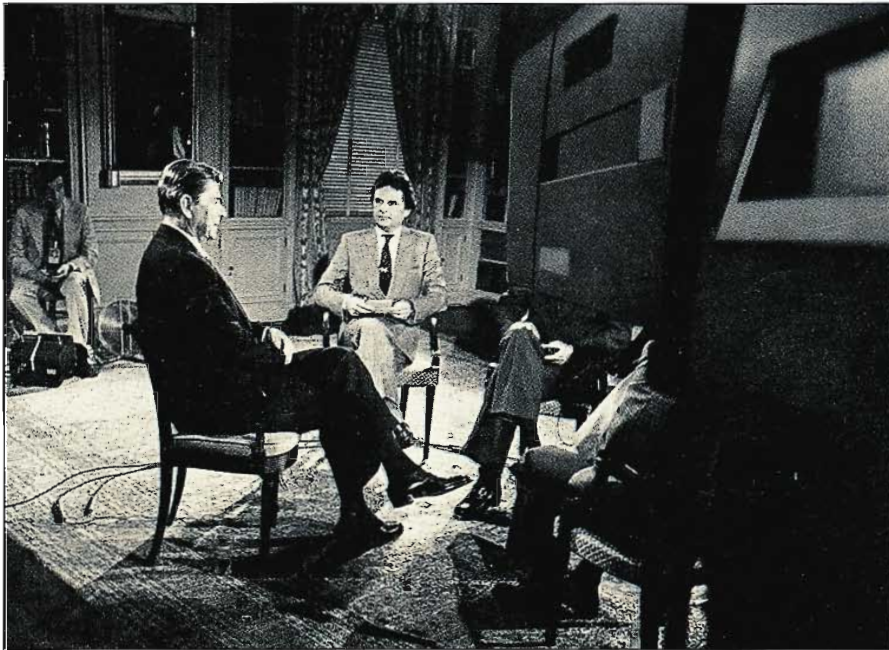

race. I don't know of any other company that could provide that kind of support."

RCA support was a key factor in choosing the TK-47 over competitive triax cameras reports Eric Address, Director of Engineering. "In the remote video production business you must have dependable service and parts. RCA does a beautiful job of backing up their equipment."

Other major factors contributing to the TK-47 purchase decision were "the camera's superior colorimetry and extended automatics."

### Remote Report

And how are the 47s proving out in the field? Steve Kurtz reports, "They've gone through some rough handling. They've been taken apart and put back together at each site. In Charlotte our 47s operated in temperatures up to 135°F; in the Poconos it was windy and raining. The cameras gave us consistently beautiful video. The automatics are fantastic . . . to set-up you just hit a few buttons."

Clients using Stewart remote facilities see TK-47 automatics and triax features as real time and cost saving advantages states Sten Leshner, V.P. Mobile Facilities. "The automatics make it a lot easier to set the cameras. You just turn them on and the computer does the registration, shading, etc. Everything is done from the terminal. At Charlotte and the Poconos—we used the pre-installed cable to pit areas. We also had to lay about 8,000 feet of triax, but it went down a lot faster than any other cable would."

Leshner adds, "It seems like jobs are coming out of the woodwork since we hit the road with the 47s. We like the cameras and we're happy with the way they're helping bring in new business."

# WOR-TV WINS AT BASEBALL WITH SIX

During the 1982 baseball season WOR-TV received special recognition for the unusually good quality of its New York Mets telecasts. The independent VHF superstation won the 1982 award for "Outstanding Telecast of a Local Sporting Event" from the New York State Broadcasters Association.

"Yes, things have worked out well for WOR at Shea Stadium," states Ken McGowan, the station's new Director of Engineering.

We have a talented, innovative production staff, and an expert technical crew and we're getting excellent picture quality from our six TK-47 automatic cameras."

WOR-TV made the TK-47 choice four years ago. According to Lad Hlavaty, V.P. Engineering, RKO General, the decision was based on superior resolution and extensive automatic set-up capability (covering 100 parameters in all). Ken McGowan reports, "Results are extremely precise. Video quality is uniform from camera to camera . . . consistent from telecast to telecast."

WOR-TV maintains video consistency even under changing lighting conditions. TK-47

**Cameramen Richard Gordon, Steve Kent, and Frank Ginise capture the hot plays and heated action of Mets baseball with WOR TK-47s.**

**Bill Walsh, VP TV Operations, and veteran cameraman Andres Hernandez with sportscast award.**

**WOR crew add interest to telecasts with player statistics and slow-mo replays.**

**TD Art Gress watches as video operator Bob Goodman maintains full control of all six TK-47s.**

**Director Bill Webb calls the shots supported by Pam Livingston and AD Jeff Mitchell.**

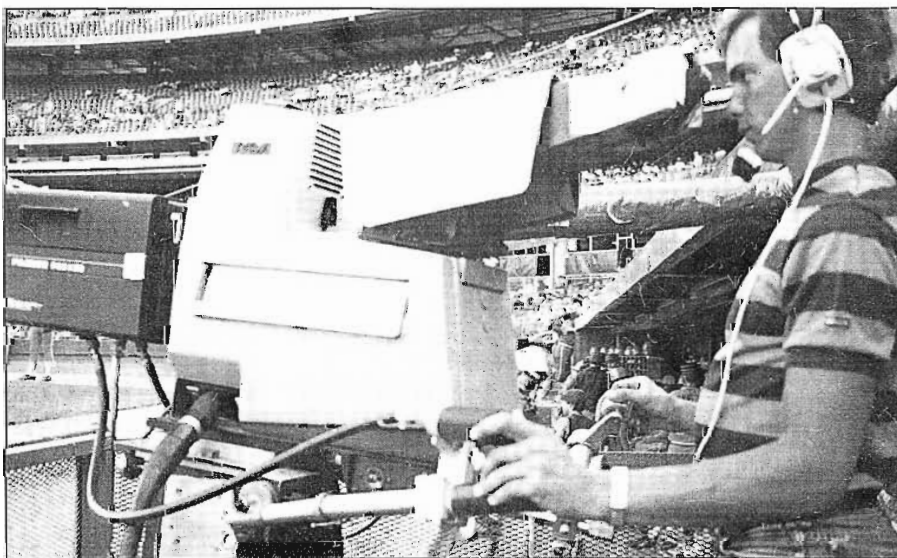
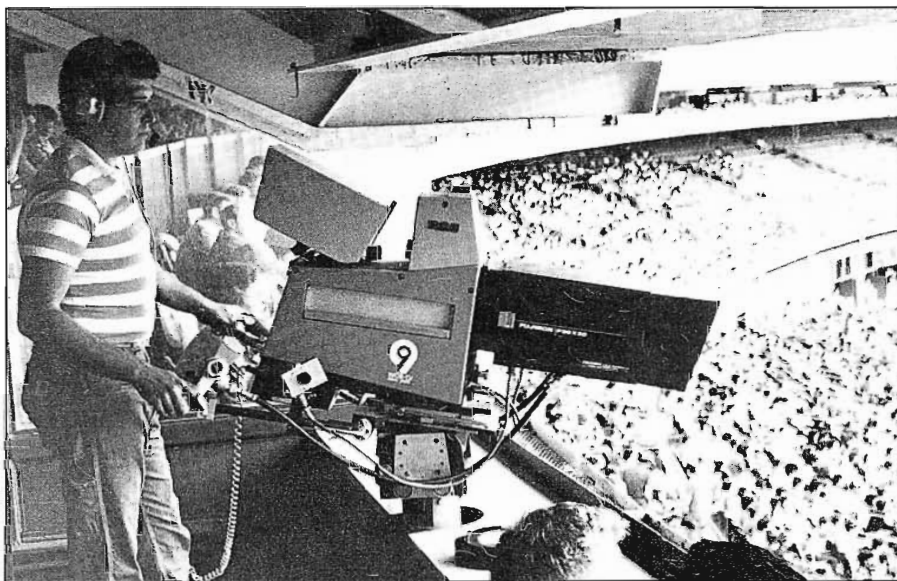



## TK-47s COVERING DIAMOND



memory files are preset for overcast conditions, bright sunlight, haze and night light. By selecting the appropriate file the proper balance for each camera is automatically set for the light encountered.

#### Meeting Creative Criteria

All six TK-47s have 30:1 lenses with 2X extenders to accommodate Director Bill Webb's penchant for experimenting with extreme close-up reaction shots and slow motion replays. Many of these are fed to the Mets controlled DIAMOND VISION, the stadium's large video screen. "Those isolated shots add excitement to key moments of the game. The Mets expect state-of-the-art video . . . and, the TK-47 delivers!" insists McGowan.

#### Saving Time and Money

Three seasons of operation have proven the production efficiencies TK-47 automatics afford. Explains Bob Goodman, Video Operator, "With our previous cameras we'd need the assistance of each cameraman for camera set-up prior to each telecast . . . the process took up to two hours. Now the entire job can be done from the set-up terminal in about twelve minutes. Cameramen are free to do other jobs. That increases our manpower."

In regards to reliability Art Gress, Technical Director, says proudly, "In the past two years we haven't had one service call at the stadium. If the technical staff has a problem they call Tech Alert. If we need a part, Deptford has it here in two hours."

Reliability, operations efficiency, and award winning picture quality have made WOR's new Director of Engineering confident that the TK-47 choice was right. He concludes, "I'm happy with the decision . . . we couldn't have done better!"



One of TV-38's two full-size remote production units.

## WSBK-TV

### Operates Eight TK-47's for Field and Studio Production

WSBK-TV, Storer Broadcasting Company's Boston outlet is an excellent example of a broadcast operation that has been able to adapt and grow without having to re-locate.

Located on a hillside in suburban Brighton, TV-38 has been able to expand its technical capabilities through careful planning, innovative facility arrangement and an on-going new equipment acquisition schedule.

The WSBK camera complement was upgraded in 1979 and 1980 with the addition of eight TK-47 automatic cameras four equipped with 16:1 zoom lenses and four with 30:1 lenses. Four cameras are used with TV-38's 40-foot mobile TV production unit which is heavily committed to remote sports coverage, including Red Sox baseball from Fenway Park and Bruins hockey from the Boston Garden. Both of these schedules are carried on WSBK-TV.

The mobile unit has been extensively utilized on a contract basis by the major networks for covering New England sports and other events—keeping the unit busy for nearly 180 shoots per year, according to Chief Engineer John Viall. (A recently-announced New England Sports Network will offer more extended coverage of Red Sox and Bruins games starting in 1983 via cable system distribution, with pickups provided by WSBK-TV.

The other four TK-47s are in the technical center, with two assigned to each of the two studios there.

#### Quick Camera Set-Ups

Camera set-up time was a critical factor in replacing TV-38's existing camera complement (TK-44s and GE-350s). Mr Viall notes that the TK-47's microprocessor-based design was a

cost-effective innovation.

"It knocked down our set-up time in the field by at least an hour, and studio set-up time was decreased by a half-hour to 45 minutes. Multiply that by 365 days and you have pretty substantial savings in the course of a year.

"The TK-47s in the field have given us a number of benefits: quick set-up, of course, plus an enhanced product, with far less noise at low light levels. This is particularly true of color shots in the dark crevices of the Boston Garden. The gain and quietness of the cameras have resulted in far superior pictures."

Another advantage Mr. Viall cites is that the big lenses provide excellent pictures, especially on baseball night shoots. The TK-47s stability in the field in varying temperatures, has also been a performance plus, he adds.

#### Microprocessor Design Keeps Pace With Technology

"The micro processor design of the TK-47 makes it a lot easier to change the parameters of the camera," Mr. Viall comments. "You can increase the capabilities of the TK-47 by adding software. That's one thing that we were very much interested in—as technology moves ahead, you can change software and keep pace."

#### Production Time Expanded

In addition to an active mobile unit schedule, TV-38's studios are also committed to a heavy production schedule. "Being an independent station," Mr. Viall explains, "we have a lot of in-house production requirements for programming as well as promotion, which keeps our studios going 5-to-6 days a week. The



Four TK-47 Remote Control Units aboard mobile unit.

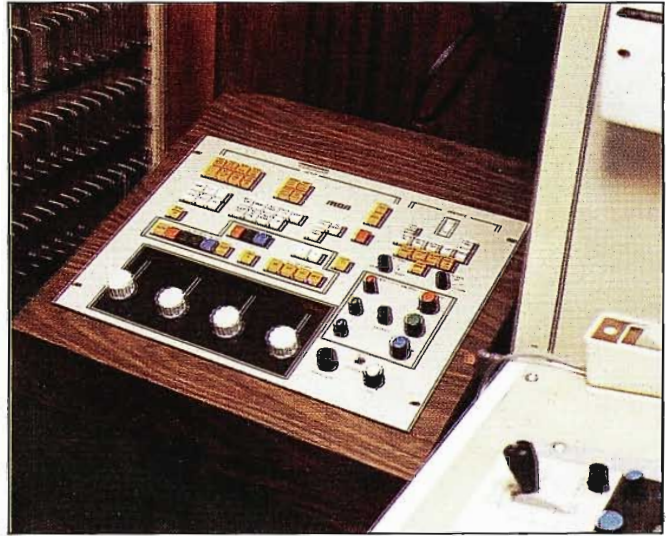

Set-Up Terminal for TK-47s is carried aboard the mobile unit.

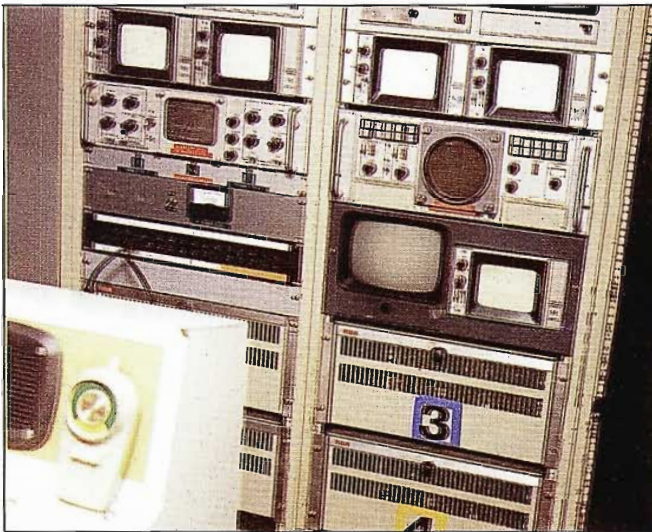

Video control—compact and efficient.



Covering Boston Bruin ice hockey action with TK-47s. Cameras move to Fenway Park for Red Sox baseball.



The TK-47's ability to handle low light levels is a valuable feature at the Boston Garden.

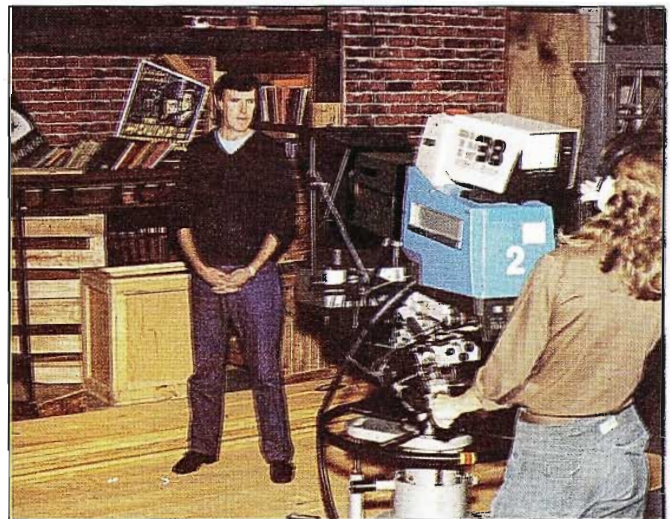

"Movie Loft" is a popular studio production.

# 4+4 TK-47 SYSTEM



Master Control for TV-38 features a "cockpit" design, with floor-to-ceiling glass, and is configured for operator comfort and efficiency.



The larger of TV-38's two Production Control rooms. Both are heavily utilized for local program and spot production.

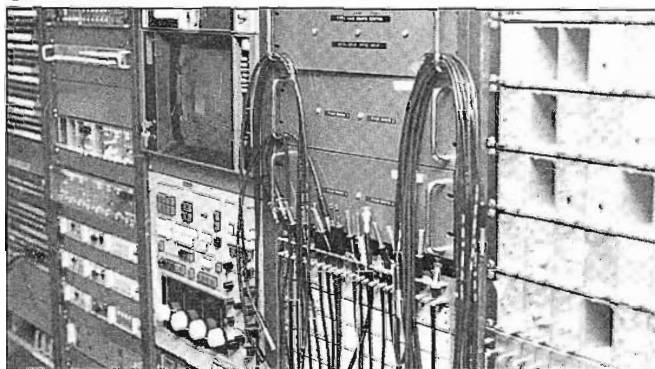

TK-47 Set-Up Terminal and CPU's (Camera Processing Unit) are located in distribution racks behind Master Control.

computer set-up for the TK-47s allowed us to expand available production time."

To illustrate the significance of quick camera set-ups in station operations, Mr. Viall noted that TV-38 airs a live program daily at 9:30 A.M. "With the fast set-up of the TK-47s, our crew can come in at 9:00 A.M. and be ready to make pictures, with time to spare. We essentially spend more time setting up audio than we do cameras."

Two Set-Up Terminals are used by TV-38 for their TK-47 cameras. One is located in the mobile unit; the other at the studio, in the terminal equipment rack area behind Master Control. The Camera Processing Units are similarly divided.

Presently the four studio camera Remote Control Units are split, with two in each of the Production Control rooms. Plans call for adding two more RCUs in the studio for more flexibility in utilizing cameras.

## Mobile Unit Operations

TV-38 operates three remote units. The TK-47-equipped 40-foot unit also carries a TK-760 camera which is frequently converted to a TK-76 portable configuration for hand-held operation. A 36-foot truck is also available for handling remotes. When schedules require, the studio-based TK-47s can be used with this unit. A smaller unit equipped with two TK-76C cameras and

3/4-inch VTRs is used for field production. (One of the TK-76s is a "floater", dispatched to whatever vehicle needs an extra camera.)

## Baseball/Hockey Coverage

"For baseball coverage, never less than four cameras, and sometimes five or six are used," John Viall says. "For hockey we usually employ four cameras and occasionally five. During hockey playoffs, when we are doing a pickup for the Canadian Sports Network (CSN) we will use eight or nine cameras and three tape machines."

In covering hockey games, two or three TK-47s are located in the "cage" looking down on the rink action. One TK-47 is post-mounted at one end zone. This season, Viall notes, a TK-760 has been added to provide iso shots of plays as they develop, to help viewers see the "big picture" of the action.

## Low Light Level Performance

Previously at the Boston Garden, separate lighting was needed in the announcer's "basket". Pulled plugs and tipped-over lighting stands occasionally interrupted their interviews. With the TK-47's ability to handle low light levels, the extra lighting is not needed. "The camera is more sensitive and less noisy at low light levels, which is a big plus for us," adds Mr. Viall.

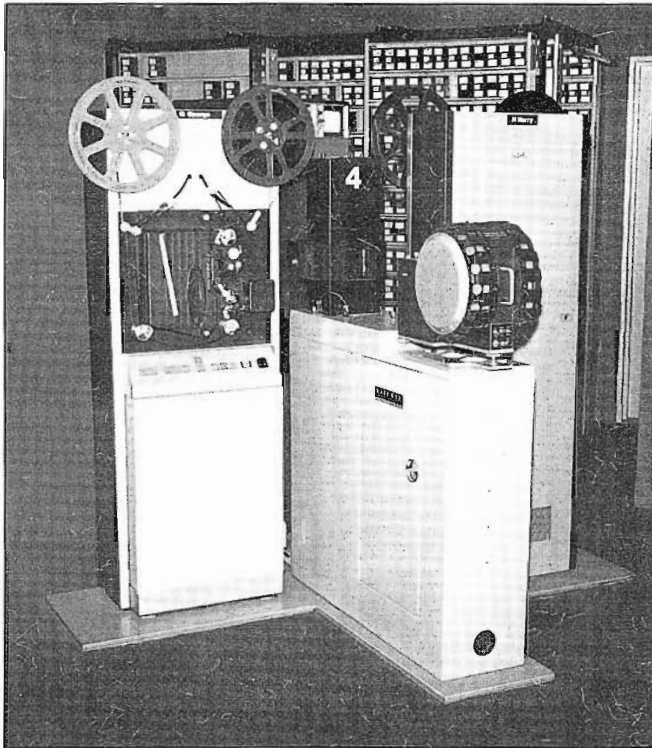

**Telecine is an active function, with five film islands in use.**



**Two TCR-100A "cart" machines handle commercial blocks—about 600 air functions daily.**

The smaller of WSBK's two studios (30' x 50') is used for promotional and commercial production. The main studio is 40' x 60' and includes permanent sets for regular productions. A daily studio production is "Movie Loft", which features a host to introduce films and provide commentary on them between each break.

### **A Popular Cable System Pickup**

With its mix of quality syndicated programs (M\*A\*S\*H; Barney Miller; Charlie's Angels; The Jeffersons), plus sports coverage, and the popular "Movie Loft" prime time package, independent TV-38 performs well in the market. It is the most widely-cable-carried station in the Boston market, and is picked up on cable systems in New York and New Jersey as well as all of the New England states.

The 41-member technical staff at WSBK is responsible for all technical services and facilities, including maintenance and manning of audio, video, cameras and master control positions. Even when handling remotes on a contract basis, TV-38 provides the crew as well as the equipment.

### **Twin "Cart" Machines Carry Heavy Commercial Load**

Along with a complement of new one-inch Type C VTRs, the station's Telecine/Tape studio facility includes two well-utilized TCR-100

cartridge tape machines which are invaluable for handling commercial blocks throughout the schedule, Mr. Viall says. "Our two TCR-100s are performing about 230,000 air functions per year—about 600 plays per day—which does not include dubs, cart transfers or production work. Our equipment is just 'hauling' all the time, and the TCRs are very reliable."

### **Independent Operation Provides A Constant Challenge**

WSBK-TV has been a Storer broadcast operation since 1966, and has been at the Brighton location since 1969. During that time, there have been four Master Control expansions and three Control Room updates—all within the same facility.

John Viall has been in the technical department and actively involved in the expansions and updates at TV-38 since 1965, and has been Chief Engineer there for the past four years. "The diversity and excitement of an independent operation provide the constant challenge that keeps the job interesting," he concludes.

# TR-800s For Century III Teleproductions' "Supersuite"

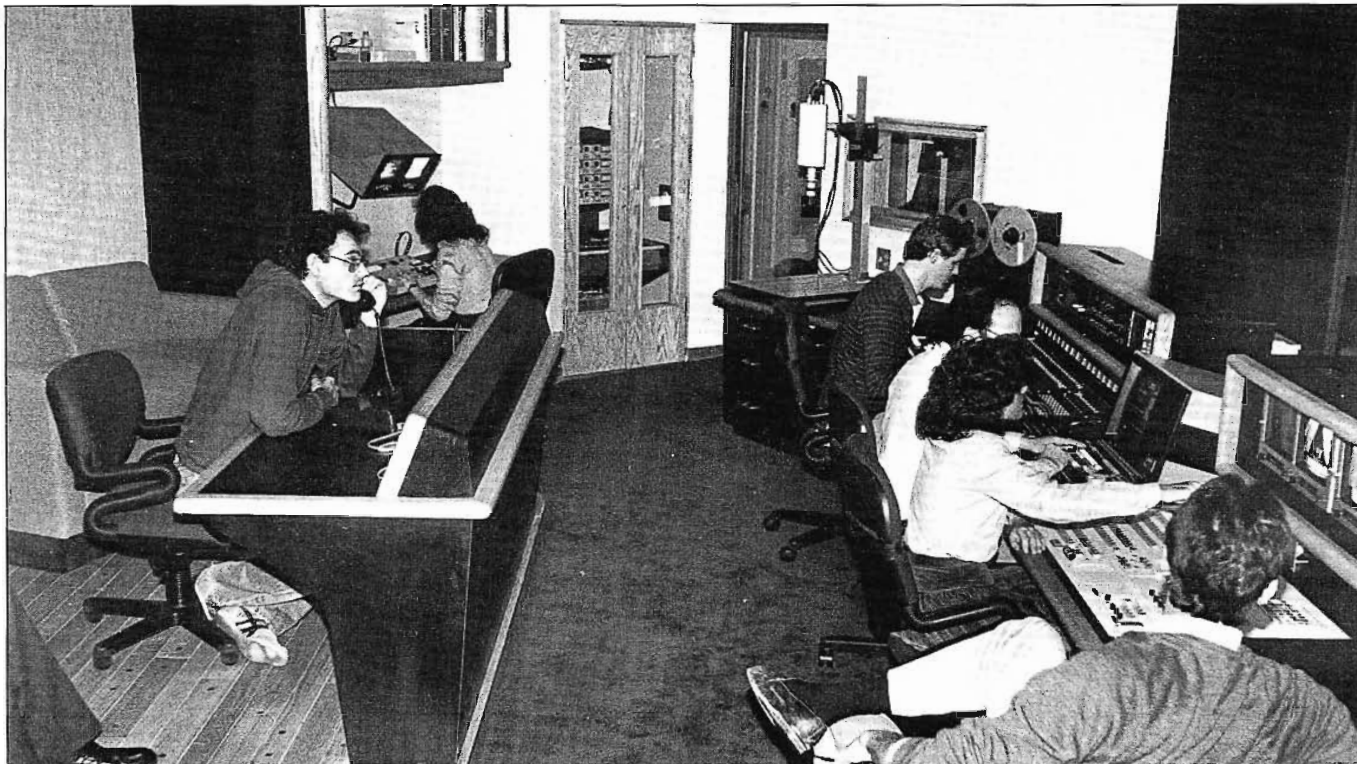

A large and fast-growing, four-year-old production/post-production house, Century III Teleproductions of Boston, Mass., has expanded its video taping and editing capabilities with over \$1 million worth of RCA equipment. The equipment includes five RCA TR-800 1-inch Type C video tape recorders, each with built-in Supertrack variable play control and optional TBC-8000 time base corrector. In addition, Century III has equipped a new "Supersuite" editing room with an RCA-supplied CMX 340X computer editor with switcher control, Grass Valley 1600 3FN switcher, Soundcraft 1600, 24-track audio console, and Chyron IV character generator with composer and

digitizer. RCA also supplied them with color correction, test, monitoring, distribution, amplifier and audio mixing equipment for the suite. Four of the five TR-800s are employed in this suite. (The fifth is interfaced with a telecine for film-to-tape transfer.)

In addition to the advertising agencies, industrial firms, and television program producers that make up Century III clientele served with this equipment array, they also serve broadcasters.

## **Boston Broadcast Business "Booming"**

"TV stations are booming right now in this market," says Lee Rubenstein, Century III's

senior account executive. "Innovative stations here are producing saleable programming; WGBH, WCVB, and WNEV are some examples. They haven't the equipment and time we have, so we're handling the overflow."

Century III Account Executive, Judy Downes says, "We've got the equipment, including the biggest and best, the latest second-generation 1-inch RCA machines." Rubenstein adds, "TR-800s were recommended by our Vice President and Director of Engineering, Richard Parent, who has always insisted that what we buy reflects our dedication to excellence."

## The TR-800 Decision

Richard A. Parent came to Century III in 1979, with an extensive broadcast background. Says Parent, "Through my broadcast years I've used a lot of RCA equipment and always had a good relationship with RCA. I did not expect RCA to service a production company so well. RCA was in charge of the contract for all of the equipment in the Supersuite room. Between the expertise they'd offered me in the past and my own experience in evaluating the TR-800 over a two-year period of time, we decided to go with RCA."

Parent points out, "When I looked at TR-800s, I saw that no other machine to date had been so well designed for editorial use. No machine but TR-800 had been designed to absorb the constant abuse of editing; capstan in and out, bang, bang, bang, around the clock. The TR-800 is designed for that purpose. The TR-800 transport will handle the punishment of being energized, and de-energized over thousands and thousands of cycles."

Having compared TR-800 to other 1-inch machines, Parent notes, "I didn't particularly want a machine to 'talk' to me, and I've had some unfortunate experiences with product support from some (import-brand) manufacturers."

Detailing his company's experience with RCA equipment, Parent says, "Our three original RCA TR-600A quads have been in constant use since our start up (in 1979). We shoot our highest quality commercials with RCA cameras. I can get any needed parts in four hours. Tech Alert advice is very good. RCA manuals are probably some of the best ever put out. RCA training is fine, too." He sums up, "RCA's TR-800 is *right*. When the edit suite is going at its dollar rate per hour, and it goes 18 to 20



hours a day, with those TR-800s turning, we're turning a profit!"

## TR-800 Use Yields Increased Creativity, Confidence

Don Roy, Editor at Century III, finds increased creative freedom with TR-800 use. Says Roy, "When we get into a creative mode we often show the client still frames. The TR-800s let us go into freeze-frame different ways. You can hit it and go into it very slowly or edit to it, then stop the edit in an instant, then bring

Century III's massive Supersuite editing room can comfortably hold 15 persons. (opposite page)

Richard A. Parent, vice president and director of engineering, with four of the five Century III RCA TR-800s.

Three RCA TR-600A Quad VTRs have been Century III's "workhorses".

## TR-800 "Supersuite"



One of Century III's TR-800s is assigned to handle film-to-tape transfers.

Supersuite's elaborate audio facilities include a 24-track audio console.

it to life."

"The vary speed (variable play speed control) is right on line to fit a 32-second spot into 29. In the past, (with outboard time compression) it would work one out of five times. Clients would look at all the glitches and pops. Then you've lost your client's confidence. You can feel it. I like keeping the rapport. The TR-800 allows me real creative choices. It helps the entire edit. RCA's TR-800 can, in longer shows, reel after reel, give me the same picture every single

time. For 1-inch that's very hard to do without color frame shifts, hops, 'blinkies'—there are all sorts of names we call them. The TR-800 will lock up that picture, lock up on the same frame *every* time."

Robert Flood, Century III editor, agrees with Don Roy's assessment of the TR-800. According to Flood, "The speed of the machine is unbelievably useful. The ability to shuttle through a reel so quickly . . . (90 seconds for an hour reel) is really nice. And TR-800's time compression ability is a big plus. In actual recording, the pictures the machines produce look flawless."

### Supersuite: Redefining State-of-the-Art

Ross Cibella, president of Century III, talking about Supersuite says, "State-of-the-art is no longer enough. Every production house that adds equipment says it is state-of-the-art. We have had to redefine this concept." The result of Cibella's goal is an editing room large enough to hold 15 people, and accommodate each of them in luxurious comfort while they perform their tasks. The room is outstanding in appearance and is designed for function and human engineering.

Century III's Vice President, Richard Parent says, "When we built Supersuite it was a culmination of things that clients had demanded in other suites. Supersuite was designed to take on more production, in more production areas than before. It's an audio *and* video suite. We can do audio mixing of up to 24 tracks. It's got four TR-800s in it. It could, in future, have six TR-800 machines in it. The TR-800 is right for our 'high pride' suite."



LIVE OR ON TAPE . . .

# TELEAMAZONAS' MOBILE TV UNIT

BRINGS IN THE ACTION



A familiar sight in many parts of Ecuador is this Teleamazonas Mobile television unit.

From Quito and Guayaquil and numerous remote points in between, the Teleamazonas mobile television vehicle covers a lot of ground in Ecuador, to bring a full schedule of sports and entertainment programming to its viewing audience.

For nearly two years, the RCA-built compact production unit has been in action, operating from the Channel 4 studio in Quito.

Chief Engineer Tony Escobar notes that the vehicle is extensively used for televising

sports (soccer) and live productions (musicals). "Most of the time we send the signal via microwave to the studio, where the signal is recorded on one-inch VTRs for editing before broadcasting."

Fast set-up is one feature of the Teleamazonas mobile unit that Mr. Escobar appreciates. "The time needed to set up the unit for remote production depends on the location and the manpower," he says, "but for a soccer game, for example, the unit is ready in thirty minutes."

The mobile TV unit is a complete, self-contained system, equipped for handling production and post-production. The on-board equipment complement includes three TK-760 color cameras with 14:1 zoom lenses; Grass Valley switcher with special effects; an 8-channel audio console, and two ¾-inch recorders with Time Base Correctors. Two power generators and microwave transmission system are also integral to the vehicle.

Some remote productions

# Mobile TV—Ecuador

are recorded on the ¾-inch VTRs, with playback through the TBCs microwaved to the studio for delayed on-air broadcast or for recording and editing on the 1-inch machines.

According to Mr. Escobar, the station plans in the near future to replace the ¾-inch tape units now on the mobile unit with new 1-inch machines which will provide improved video quality and versatility.

The Teleamazonas Mobile TV unit was equipped, wired and custom-assembled at RCA's

Custom Repair and Assembly (CRAE) facility near Camden, N.J. The vehicle itself is built on a Ford chassis, with a powerful 460 cu. in (7.5L) engine, automatic transmission and four-wheel drive. A specially reinforced suspension system gives the electronic equipment on board a comfortable ride, even when rolling over rough terrain. The body of the vehicle is of tough, lightweight fiberglass with double-wall construction, including a full inch of bonded polyurethane foam

insulation.

"The unit has been very reliable and is giving us excellent results. We are very pleased with it," Mr. Escobar states. He is also pleased with the technical support and ready availability of parts from RCA. As an example, he notes that when a camera module in the TK-760 required replacement, it was ordered by telephone from RCA Parts depot in Deptford, N.J., and the new unit was delivered to Quito within 48 hours.



Setting up at the soccer stadium for microwave transmission. On most remotes such as soccer matches, set-up takes 30 minutes or less.

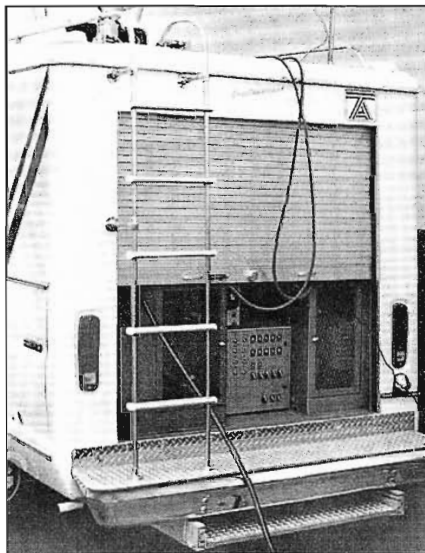

Built-in power generators and camera cable reels are mounted at the rear of the unit.



Three TK-760 color cameras are carried aboard the mobile unit.

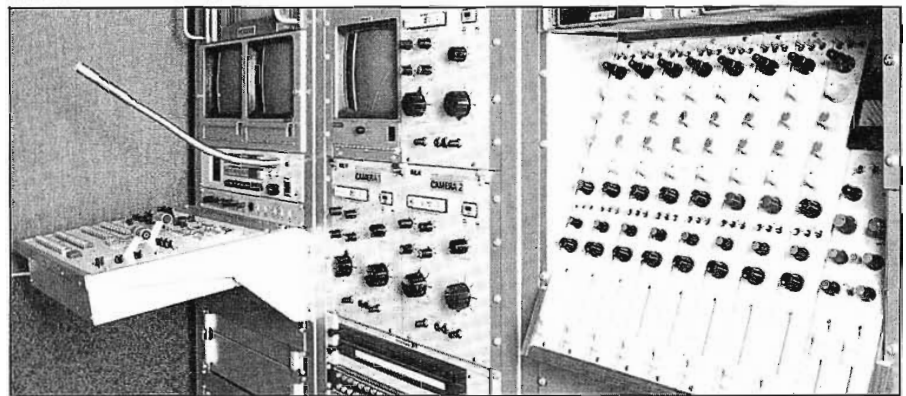

Interior view of the Teleamazonas mobile unit.



Special Delivery: Fully equipped and ready for action, the Teleamazonas Mobile TV unit rolls out of a cargo plane.

# TV TRANSMITTER SOLID STATE DRIVER BIASING TECHNIQUE

W. M. Boyd

RCA Transmission Systems Engineering

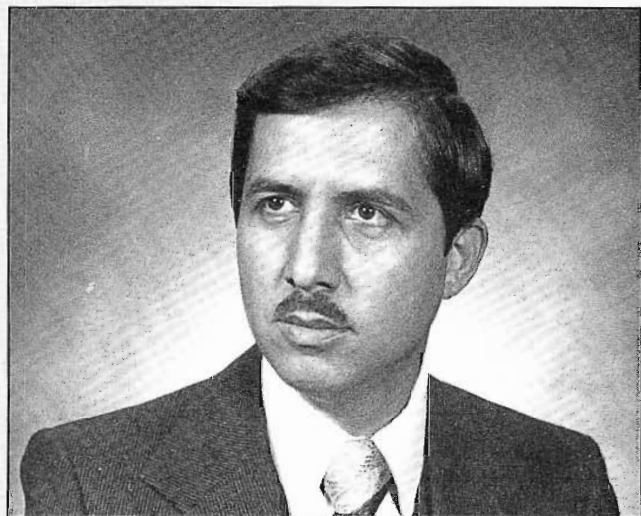

## William M. Boyd

William M. Boyd received his B.S.E. degree in 1962 from Virginia Polytechnic Institute of Blacksburg, Virginia and joined RCA Defense Electronics Products Division of Cambridge, Ohio. While at RCA DEP he was involved in the engineering and production of AN/WIC voice communications equipment for shipboard applications. He transferred to RCA's Radiomarine Products Division located in Meadow Lands, PA in early 1964 as a design engineer for shipborne surface radar systems.

Mr. Boyd joined RCA Broadcast Systems in 1965 as a design engineer for Television Transmitter Products and became Engineering Leader on the design and development of a new all solid-state exciter modulator and 1600 watt driver system for RCA's G-Line series of VHF TV Transmitters. The developments described in this paper resulted in a significant improvement in overall system performance standards for high power VHF solid-state drivers. In addition, he was the Project Leader on other VHF and UHF solid-state exciter and high power RF amplifier designs currently in use in RCA products. He has been awarded a number of patents related to his recent design activities.

Mr. Boyd is now located in Pennsauken, N.J. as an Engineering Manager in the Television Transmitter Engineering section of RCA Broadcast Systems.

New technological philosophies and advances have been made in TV Transmitter Engineering with the development of a new 1600W, all Solid-State TV driver. This high power driver was developed for RCA's TTG family of lowband and highband VHF TV Transmitters which are compatible with worldwide broadcast standards. The solid-state design to achieve in excess of one Kilowatt of linear power at VHF frequencies was a task previously reserved for vacuum tubes. The driver system concept employs a minimum number of output amplifier stages to achieve rated peak-of-sync power. This is made possible by recently developed high frequency bipolar transistors and FET devices capable of producing the highest linear output power available today in the television spectrum. However, achieving linear high power solid-state circuits required new developments in solid-state device biasing techniques.

A discussion of a biasing corrector circuit technique is presented here. This patented design provides a bias adjustment responsive to TV signal power levels—overcoming inherent solid-state device bias shifting in amplifier operating classes other than Class A.

## Driver Amplifier Design

The high power solid-state amplifier design in the TTG Driver presents the same design requirements of the output tube stage (i.e., a low-distortion but high peak-of-sync power capability). However, there is a clear trade-off between delivering maximum output power and achieving optimum linearity. To meet these requirements simultaneously, today's tube and solid-state designs typically operate near or at Class AB. Recently developed transistors including RF devices purchased to RCA specifications have resulted in linearized Class AB circuit designs of 150W for highband and 200W for lowband. These peak-of-sync power levels produce the highest linear output power available. The total system linearity is such that the driver measures only a few degrees of incidental phase and a few percent of differential gain with about 35 percent black power picture efficiency—including the Class A predriver stages.

## RF Transistor Operating Modes

RF amplifiers (Tube or Solid State) may operate at Class A, AB, B, or C. The Class A mode is necessary for ultralinear applications requiring up to -60 dB IMD distortion products below sync level—such as multiplex or transposer applications. Class C bias is used for high efficient CW applications when linearity is not important. The linearized Class AB mode was selected for the G-Line driver output arrays after an extended development program comparing alternate approach designs. The result was a push-pull module count of 12 for highband and 8 for lowband. If Class A were used, as many as 32 to 48 modules would be needed.

The resulting low solid-state module count and simplified combining network resulted in a reliable and cost effective design. Reliability was enhanced due to the low parts count, maintaining low junction temperatures, lower power supply output requirements and less stringent cooling requirements.

However, it was established that special biasing considerations were necessary for Class AB bias in the solid state amplifiers when compared to Class AB bias in high power tubes (for TV visual applications).

## Linearity Variations with APL in Solid-State Devices

It is well known that with device dissipation changes, there are inherent transistor "heating effect" thermal changes for solid-state devices operating at modes other than Class A bias. The junction thermal changes will result in small differential gain (DG) variations versus average picture level (APL). Data taken on various other (non-RCA) solid-state amplifier designs intended for TV use, and a review of related technical papers on the subject verified similar DG versus APL variations (see Figure 1). Additionally, a review of competitive TV transmitter specifications indicated the requirement for two linearity (DG)

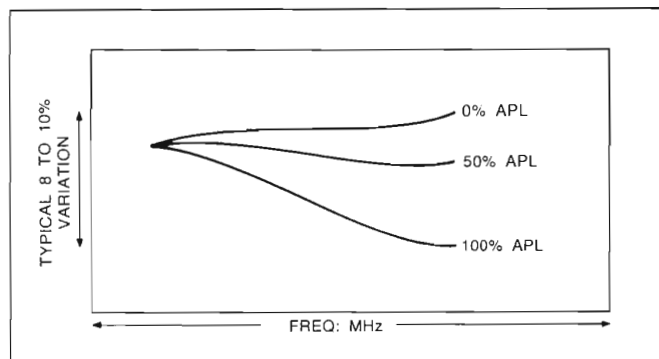

**Figure 1. Typical DG versus APL Variation for non-RCA Amplifier (i.e. no APL correction)**

specifications (i.e., one specification at 50% APL with a second higher specification for DG over APL changes from black to white). It was noted that uncorrected DG vs APL variations in other solid-state modules were generally higher than the RCA modules. This was possibly due to differences in baseplate cooling methods and bias circuit design.

Therefore, certain circuits were implemented in the TTG Driver which resulted in essentially no DG versus APL variation. It was felt that this linearity variation should not be ignored in RCA's design to maintain optimum system linearity and performance.

Various corrector circuit approaches were analyzed towards a bias adjustment design which would be responsive to changes in visual signal power levels. This design resulted in a bias correction technique which was patented.

## Thermal Effects in Solid-State Devices

All solid-state devices operated in a Class AB mode (and some other modes other than Class A) which are subjected to changing power levels (or the initial application of power) exhibit corresponding changes in the transistors junction temperature. This junction temperature shift in a bipolar device, for example, directly causes a base-to-emitter (VBE) voltage change and resulting bias shift (see Figure 2).<sup>1</sup> This new operating point of the transistor results in a movement from the initial optimum linearity setting of flat differential gain. Therefore, the temperature—dependent VBE movement with power level necessitates a corresponding bias adjustment. This bias adjustment can be easily accomplished by applying a small correction voltage of appropriate polarity which is ultimately fed to a bipolar transistor base or to a field effect transistor gate to maintain constant linearity.

It should be noted that there are low impedance bias devices and thermistor networks available which compensate for VBE with slow time constant heat sink temperature changes.

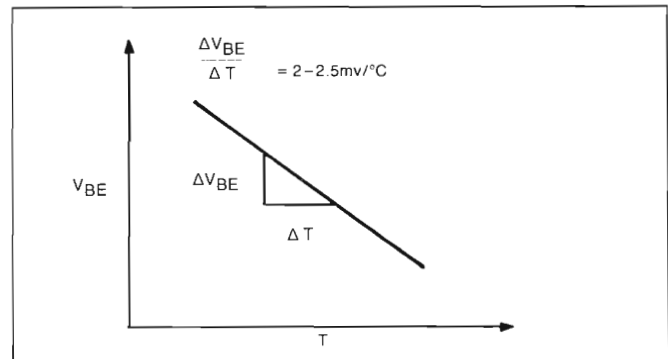

**Figure 2. Change in VBE With Temperature**

These bias devices are mounted in close proximity to the RF transistor on the same heat sink, thus preventing D.C. thermal runaway.

However, very fast temperature changes in the junction and case cannot be detected unless a compensation diode (or base-emitter junction used as a diode) are part of the same ceramic and case. Such an arrangement was accomplished by RCA Semiconductor Division some years ago with SSB epitaxial planar transistors.<sup>3</sup> These devices contained a transistor and diode pellet in the same package for transistor bias point control. However, to our knowledge, such devices are not available today in high frequency RF units and probably are not practical from an industry demand and cost viewpoint.

There are three predominant "heating effect" thermal time constants occurring with varying picture conditions within the transistor chip and its surrounding environment. The relative speed of these time constants is listed as follows:

Temperature Change Area	Relative Time Constant Speed
1. Transistor Junction $\Delta T$ (including substrate ballasting resistors)	Fast—usec's to msec's
2. Transistor Case (package) $\Delta T$	Medium—msec's to sec's
3. Transistor Heat Sink $\Delta T$	Slow—sec's to min's

Some exponential time constant values can be predicted from vendor data (see Figure 3). For example, the junction temperature time constant of a E10-28 bipolar device shows a junction reaching 90% of its steady state temperature rise in about 10 msec.<sup>2</sup> However, many time values are difficult to predict due to many solid-state device variables and must be addressed by measurement or determined experimentally. The following list relating to solid-state device construction and environment affect the listed thermal time constants:

- chip geometry
- cell structure or spacing

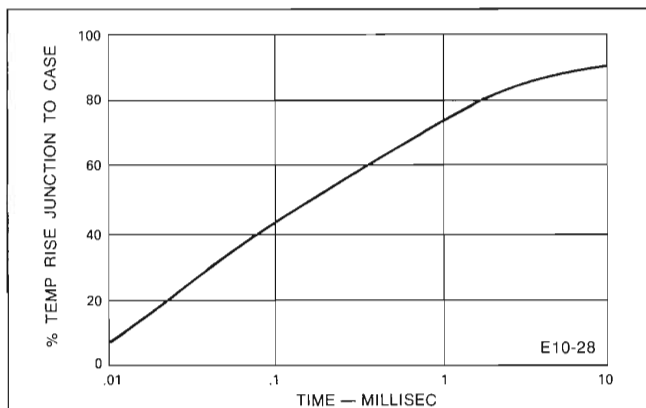

**Figure 3. Percent Rise in Junction Temperature Versus Time Application of Power for E10-28 (10W, 2 GHz Transistor)**

- substrate material
- ballasting resistor type
- package configuration—stud, flange, etc.
- thermal interface—junction to case
- thermal interface—case to heat sink
- heat sink baseplate—size, shape, cooling

It was determined during the TTG transmitter solid-state design program that the DG versus APL variation could be maintained for various semiconductor device types. Also, circuit variations in the corrector design provided correction for fast, medium or slow thermal time constants. It was observed that the very large mass "heat pipe" heat sink temperatures stabilized shortly after turn-on (1-2 minutes) and moved relatively small amounts in temperature thereafter with APL. CTC (a division of Varian Associates) has shown that flange to heat sink temperature differences stabilized in approximately 20 seconds and higher for certain RF devices.<sup>4</sup>

However, the device junction and package temperatures change constantly as noted earlier. This resulted in a final DG versus APL connection circuit providing two fast and medium (usec and msec) time constant correction voltages to the output solid-state amplifiers. A simplified corrector block diagram is shown in Figure 4.

### Bias Adjustment Circuit Description

As illustrated in Figure 4, a visual RF sample is applied to an envelope detector providing a sync-negative demodulated video signal. The detected video is then integrated producing a D.C. voltage proportional to picture APL. The DC output of the integrator is signal inverted and shaped (using an antilog function module) to provide a transfer curve of bias correction ( $\Delta V$ ) versus APL for the particular RF semiconductor devices in the driver design. A typical test setup is to adjust for zero correction (Reference) at mid-characteristic (50% APL) and provide a small increasing positive-going

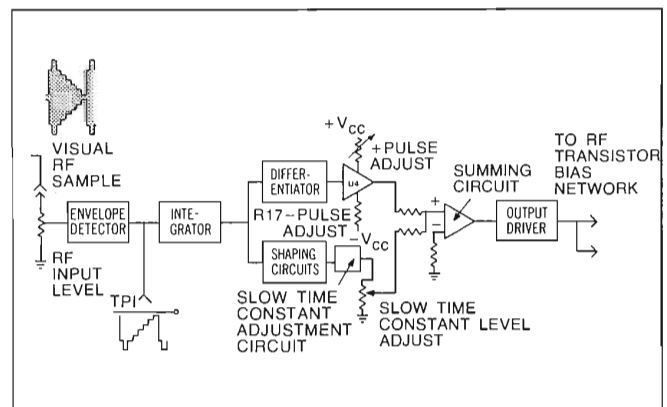

**Figure 4. Differential Gain/APL Corrector Simplified Block Diagram**

# DGAPL CORRECTOR CIRCUIT

voltage toward white picture (100% APL) and a small negative-going voltage toward black picture (0% APL). A typical medium time constant correction voltage versus APL curve is shown in Figure 5.

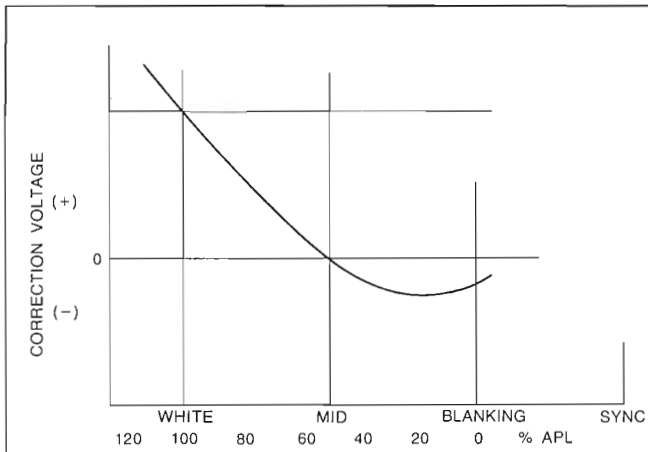
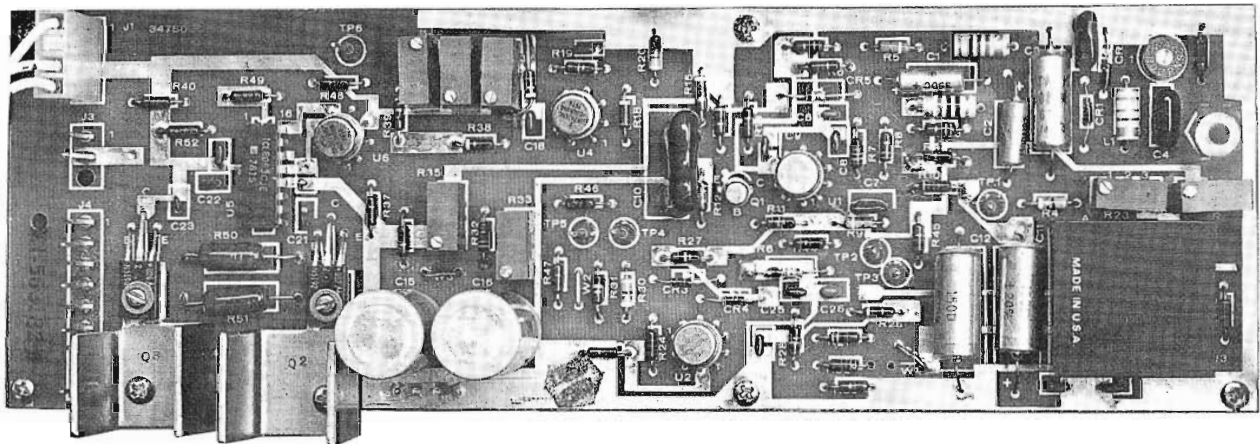

**Figure 5. Medium Time Constant Correction Voltage Curve**

The DC output of the integrator is also applied to a high speed and adjustable time constant (TC) differentiating circuit where any rapid APL transitions will produce fast time-constant correction pulses. The polarity of the pulses is dependent on whether the abrupt power transition is from black to white or vice-versa.

The plus and minus pulses are next amplitude-adjusted depending on the amount of correction desired. The resulting medium TC correction voltage for transistor case thermal changes (and bias shift) and fast TC correction voltage for transistor junction thermal changes (and bias shift) are fed to a summing stage and low impedance output driver amplifier. This DG/APL DC correction voltage is then fed to the bias networks of N number of class AB biased amplifier stages.

A photograph of the printed circuit corrector board is shown in Figure 6.



**Figure 6. Printed circuit corrector board**

## Summary

Today's high power, solid-state TV driver designs whose peak-of-sync power levels exceed 1.0 kW require a linearized operating mode other than Class A for optimizing reliability, linearity, peak power capability and efficiency. Inherent in all solid-state RF devices of these operating modes exists DG versus APL bias shifts which should be addressed for utmost TV linearity performance.

A new compensating circuit approach to

correct for such small DG changes has been developed to maintain a low distortion operating point; thus, correcting for VBE changes as caused by thermal changes in the semiconductor junction and case. Additionally, the circuit responds to the rate of change of TV signals. The RCA TTG Solid-State Driver is the first design to achieve 1.6 kW and address the inherent thermal changes and time constants to maintain differential gain specifications over varying APL conditions.

## REFERENCES

1. Hunter, Lloyd P., "Handbook of Semiconductor Electronics" Second Edition, 1962.
2. "Solid Circuits, Communications Transistor Company Application Book 2.2.8.0A, 1973.
3. "Transistor, Thyristor and Diode Manual", RCA Technical Series SC-15, 1971.
4. Bartlow, H., "Thermal Resistances Related to Flange Package Mounting", C.T.C. Applications Note 2.0.8.2B, 1976.

# ON THE ROAD . . . AROUND THE WORLD

## RCA Mobile TV Units: Versatile, Performance- proven Video Systems

Hundreds of RCA mobile video production systems are now in use around the globe. RCA has been designing, equipping and delivering them for more than thirty years.

Compacts and trailers; busses and box-bodies. Custom-built by RCA, they come in a wide variety of layout configurations and with equally varied equipment complements. A leading world-wide supplier of these systems, RCA has the experienced staff, the facilities and the resources to handle any user requirement.

**FOR EXAMPLE:** The 45-foot QVLV (Quality Video of Las Vegas) trailer is a giant among mobile TV units, with total video production capability. The custom-designed, four-compartment system carries 8 cameras (6 TK-47 Triax Automatics); 6 video tape recorders (4 TR-800, Type C); 24-input video switching with video effects; 48-input audio, and all of the metering, monitoring, and communications facilities needed to handle the most complex field productions.

**ANOTHER EXAMPLE:** The compact van—an exclusive RCA design. Just under 19 feet long, it is nimble enough to flow with city traffic and to fit into tight parking spaces. Yet it has the stamina for cross-country travel. Its flexible design accommodates a full range of equipment variations and layouts with every capability required for on-site origination and taping.

Before you start the wheels turning on any mobile TV project, check out RCA's full service plus capability. Contact your RCA Representative. Or write RCA, Bldg. 2-8, Camden, NJ 08102.



# RCA



**KENT BOWLDS**  
EFP Operator, on location in  
Natchez for Mississippi ETV